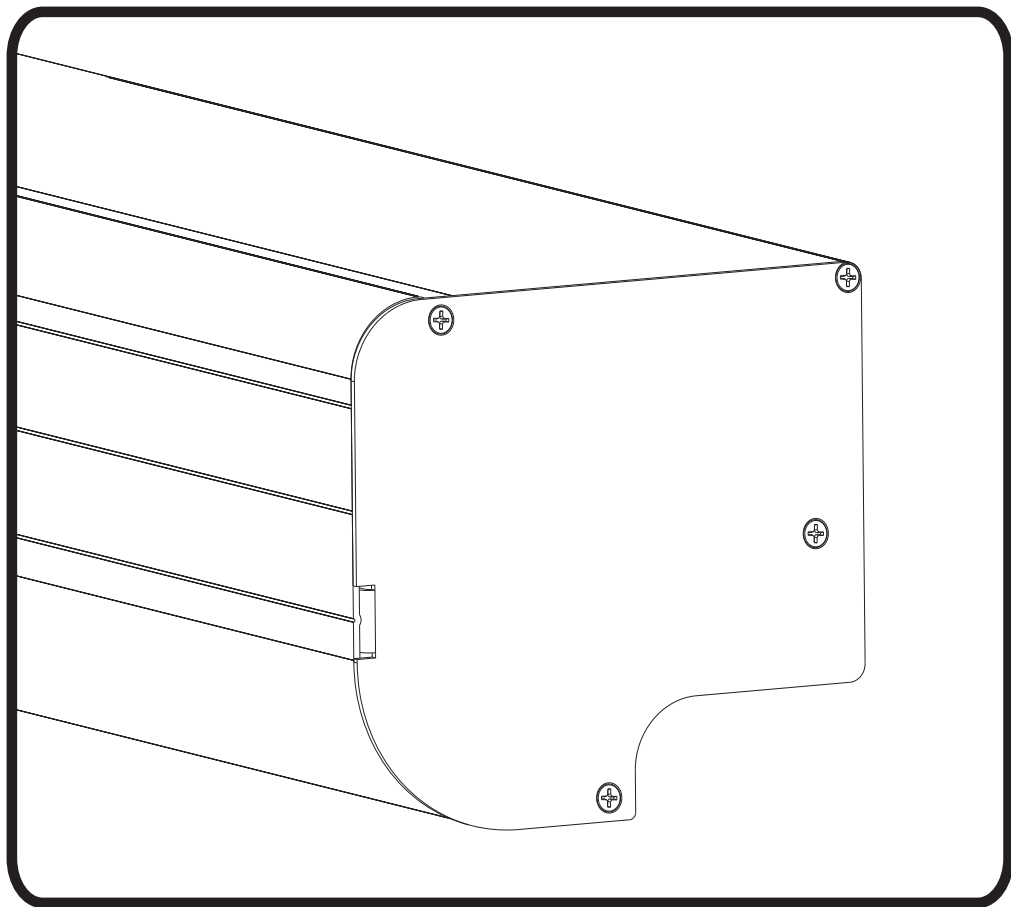


AUTOMATION AND ELECTROMECHANICAL DRIVERS  
FOR LINEAR SLIDING DOORS WITH ONE OR TWO PANELS

K240



*installer's manual*



COD. 0P5411

VER 0.0

REV 09.11



**1- GENERAL INFORMATION**

1.1- General recommendations.....	pag. 04
1.2- General safety rules .....	pag. 04
1.3- Installer .....	pag. 04
1.4- User .....	pag. 05
1.5- Warranty.....	pag. 05
1.6- Servicing .....	pag. 05

**2- TECHNICAL DESCRIPTION**

2.1- Rating place and "CE" marking .....	pag. 05
2.2- Proper use .....	pag. 05
2.3- Technical data .....	pag. 06
2.4- Packing .....	pag. 06
2.5- Models .....	pag. 07
2.6- Sliding doors with one panel .....	pag. 08
2.7- Description of parts and dimensions .....	pag. 09

**3- INSTALLATION**

3.1- General recommendations.....	pag. 11
3.2- Installing the crossbar .....	pag. 11
3.3- Installing the adapter and track.....	pag. 12
3.4- Installing the carriages on the door.....	pag. 13
3.5- Fastening and adjustment of the sliding panels.....	pag. 14
3.6- Installing the motor module, belt transmission, belt,logline.....	pag. 16
3.7- Fastening the drive brackets on the door panel.....	pag. 18
3.8- Installing the door block .....	pag. 20
3.9- Installing the casing .....	pag. 21

**4- ELECTRICAL CONNECTION**

4.1- General recommendations .....	pag. 22
4.2- Electrical connection.....	pag. 22
4.3- Electronic circuit board .....	pag. 22
4.4- Pre-wired electrical connections .....	pag. 24
4.5- Connection of program switch to MS1 knob .....	pag. 25
4.6- Collegamento selettore digitale DS1 .....	pag. 25
4.7- Connection of single and double beam photocells .....	pag. 26
4.8- Connection of key device.....	pag. 26
4.9- Connection of detection sensors .....	pag. 27
4.10- Connection of emergency key .....	pag. 28

**5- USE AND OPERATION**

5.1- Technical description .....	pag. 29
5.2- Emergency battery .....	pag. 29
5.3- Reset procedure.....	pag. 29
5.4- Programming parameters .....	pag. 30
5.5- List of messages and alarms .....	pag. 31
5.6- Program selection knob .....	pag. 32
5.7- Digital switch .....	pag. 33

**6- APPENDICES**






6.1- Maintenance .....	pag. 34
6.2- Spare parts and optional accessories.....	pag. 34
6.3- Demolition .....	pag. 35
6.4- PTroubleshooting.....	pag. 35

7- "CE" TYPE B CONFORMITY CERTIFICATE .....	pag. 36
---	---------









## 1.1 GENERAL RECOMMENDATIONS









Before installing the automation the installer must read and understand all parts of this manual.

-  This manual is an integral part of the automation unit and must be kept by the installer, with all the enclosed documentation, for future reference.
-  This manual provides all instructions necessary to ensure correct installation and maintenance of the automation: TOPP spa is not liable for any damage to persons, animals and property caused by failure to follow these instructions.
-  This manual was written by TOPP spa, which holds the copyright. No part of this manual may be reproduced or published without the manufacturer's written authorization.
-  TOPP spa reserves the right to amend or improve the manual and the products described therein at any time without notice.
-  The data contained in this manual were written and checked with the maximum care; TOPP spa is not liable for possible errors due to omissions or printing errors, or errors in transcription.

## 1.2 GENERAL SAFETY RULES

-  The personnel must be informed of the risks of accident, about the safety devices for the operators and about the general rules for accident prevention foreseen by the international directives and laws in force in the country in which the automation is installed. In any case, the personnel must comply scrupulously with the safety regulations for prevention of accidents in force in the country in which the automation is installed.
-  Any tampering with or unauthorized replacement of parts or components of the automation mechanisms and any use of accessories or consumables other than the originals may represent a hazard and relieves the manufacturer of any civil and penal liability.
-  Operations of routine and special maintenance requiring even partial removal of the automation, should be performed only after disconnecting power to the automation mechanism.
-  Do not remove or alter the plates and labels applied by the manufacturer on the automation and its accessories.
-  Never try to oppose the movement of the door and work near the hinges or other mechanical moving parts in motion (such as belts, carriages, etc.). The manufacturer is not liable for any damages caused by improper or unreasonable use of the automation.
-  When handling electric parts always wear grounded antistatic conductive bracelets as electrostatic charges can damage the electronic parts on the circuits.
-  The automation contains mobile mechanical parts, electrical connections and electronic circuits for control of door movement; the automation must therefore be protected, along its entire length, by an aluminum casing.
-  This device is not suitable for use by persons (including children) with reduced sensorial or mental capacity or insufficient expertise, unless they are supervised and instructed in proper use by persons responsible for their safety. Children must be controlled and prevented from playing or standing in the radius of action of the door.

## 1.3 INSTALLER

-  Installation and routine/special maintenance of the automation must be done exclusively by qualified technical personnel in possession of the professional requisites foreseen by the laws in the country of installation.
-  The installer must verify compliance with the current directives and regulations on the safe use of motorized doors.
-  The installer must be able to install the automation, start it and operate it with the power on in electrical cabinets or shunt boxes, and must be qualified to perform all actions of an electrical and mechanical nature and any kind of adjustment.
-  After installing the automation, the installer must analyze the system for risks and verify that the sliding door installation does not present risks of crushing or shearing, adopting adequate corrective measures, if necessary, and applying the warning signs foreseen by the laws in force to identify hazardous zones.
-  Every installer must provide visible annotation of the data identifying the drive system.
-  The installer must also supply the owner with all information regarding automatic, manual and emergency function of the automation and deliver the instructions for use contained in this manual to the user.

## 1.4 USER

The user must be able to operate the automation under normal conditions and perform simple operations or startup or resetting the automation following any forced interruptions, using the devices provided (digital switch, analogue switch, etc.).

The user must not open the casing or perform any operations restricted to maintenance personnel or specialized experts. In case of breakdown or malfunction of the door, the user should simply switch off the circuit breaker and abstain from any attempt to repair the system.

Use of the automation must be exclusively permitted to users who comply with the instructions in this manual and in the manuals of the TOPP devices connected to it.

## 1.5 WARRANTY

The warranty on the automation is invalidated if the use does not comply with the instructions and regulations listed in this manual and if parts, accessories, spares and control system not furnished by TOPP are used.

## 1.6 SERVICING

For any technical assistance, contact your retailer or the manufacturer.

# 2 TECHNICAL DESCRIPTION

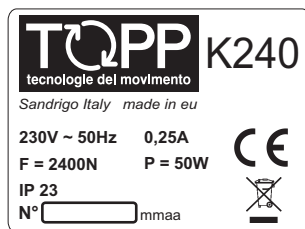
## 2.1 RATING PLATE AND "CE" MARKING

The "CE" marking certifies the conformity of the machine to the essential health and safety requisites foreseen by the European product directives.

It consists of an adhesive label in polyester, silkscreen printed in black and measuring L=50mm - H=36mm, applied on the motor unit of the automation. The rating plate contains the following data, printed legibly and indelibly:

- the manufacturer's logo and address;
- the type and model;
- the voltage (V) and frequency (Hz) of electrical power;
- the intensity of current absorbed (A);
- the maximum capacity of the automation (N);
- the electrical power absorbed P (W);
- the degree of protection (IP);
- the "CE" seal of approval;
- the Directive "RAEE" 2002/96/CE symbol;
- the serial number;
- the months and year of construction.

Fig. 1



## 2.2 PROPER USE


The K240 automation mechanism was designed and produced exclusively to operate (open and close) linear sliding doors in residential, public and industrial buildings.

It is strictly forbidden to use the automation for purposes other than those described herein, in order to guarantee at all times the safety of the installer and user and the correct function of the automation.

## 2.3 TECHNICAL DATA

Tab. 1 lists the technical data that characterize the K240 automation.

Tab. 1

<b>MODEL</b>	<b>K240</b>	
POWER SUPPLY	230V ~ 50Hz	
PERIPHERAL POWER OUTPUT	24V  500mA max	
ABSORPTION	0,25 A	
POWER ABSORBED	50 W	
TYPE OF USE	Continuous	
OPENING/CLOSING SPEED	Adjustable 10 ÷ 55 cm/sec	
OPENING/CLOSING APPROACH SPEED	Adjustable 1 ÷ 10 cm/sec	
OPENING/CLOSING ACCELERATION	Adjustable 1 ÷ 5	
OPENING/CLOSING APPROACH SPACE	Adjustable 1 ÷ 40 cm	
AUTOMATIC CLOSING TIME	Adjustable 0 ÷ 60 sec	
MOTOR FORCE	Adjustable 100 ÷ 150 N	
MAINS VOLTAGE FUSE 230V	5 x 20 - T 1,6A delayed	
PROTECTION OF ELECTRIC DEVICES	IP 23	
WORKING TEMPERATURE	-20°C ÷ +50°C	
<b>NUMBER OF DOOR PANELS</b>	<b>1 PANEL</b>	<b>2 PANELS</b>
MAXIMUM CAPACITY	240 Kg	120 + 120 Kg
SIZE OF OPENING	800+3200 mm	1000+3200 mm

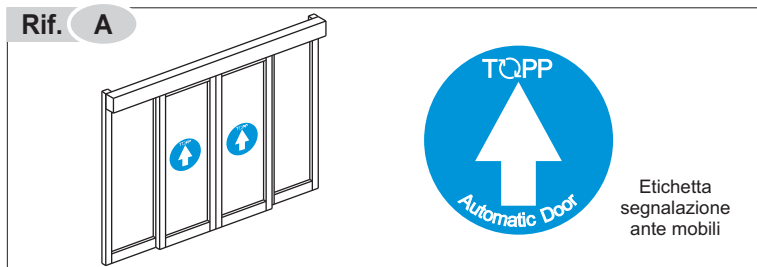
## 2.4 PACKING

Every standard product package (cardboard carton) contains:

- N.1 K240 automatic door (complete with motor unit and belt transmission preassembled on the crossbar, side caps, casing, door stop limit switch, cable raceway, emergency battery, raceway, ferrite, ferrite clamp, rubber cable sleeves);
- N.1 package of hardware consisting of 2 glide runners, 2 self-tapping screws TC d6x70 and 2 nylon anchor bolts 10x60;
- N.2 Carriage units with relative hardware for fastening to the adapter;
- N.2 Supporting brackets on the crossbar;
- N.2 warning labels for moving wings that have to be stuck on the centre of the moving wings (refer to picture A);
- N.1 Adapter for framed door panels;
- N.1 Rail for framed door panels.

Make sure the parts described above are in the package and that the automation has not undergone any damage in shipment. If you find anything unusual, do not install the automation and request the service department of the local retailer or the manufacturer.

- ∞ The number of some of the parts described above may vary depending on the type of configuration (e.g. number of door panels). If more parts are necessary, contact the manufacturer.



## 2.5 MODELS

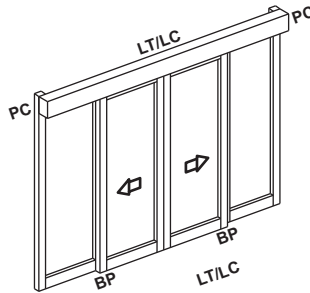
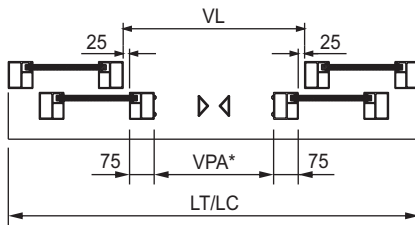
Two models of automation are available:

- automation with 2 door panels (Fig.2) which allows a pair of door panels to glide simultaneously in opposite directions;
- automation with 1 door panels which allows a single door panel to glide in one direction; Fig.3 shows an application with a single door that opens toward the right (seen from the front of the automation); Fig.4, shows a single door that opens toward the left (seen from the front of the automation).

✗ When order a single door panel application, always specify the direction of opening of the door, seen from the front of the automation.

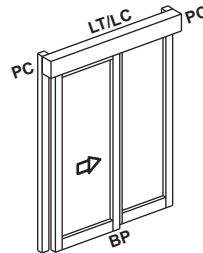
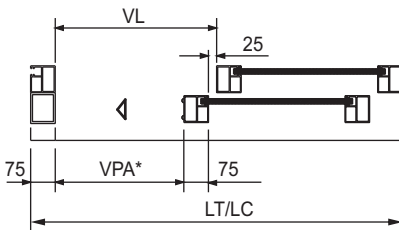
✗ To comply with the safety regulations, the glide of the door panel **VPA** must be less than the door opening width **VL**. The glide of the door panel **VPA** is equal to **VL** when the upright on the door does not have any roundings and/or protrusions that could cause a shearing effect.

**Fig. 2** 2 DOOR PANELS



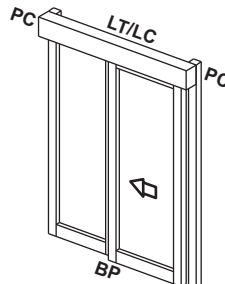
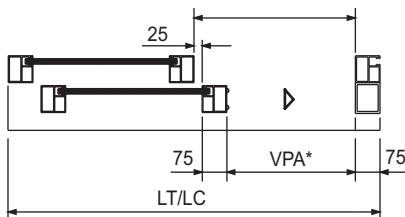
**VPA** = net doorway width  
**VL** = gross opening  
**LT/LC** = automation length / casing length  
**BP** = rail + runner on the floor  
**PC** = electric wire raceway

**Fig. 3** 1 RIGHT DOOR PANEL



**VPA** = net doorway width  
**VL** = gross opening  
**LT/LC** = automation length / casing length  
**BP** = rail + runner on the floor  
**PC** = electric wire raceway

**Fig. 4** 1 LEFT DOOR PANEL



**VPA** = net doorway width  
**VL** = gross opening  
**LT/LC** = automation length / casing length  
**BP** = rail + runner on the floor  
**PC** = electric wire raceway

## 2.6 DESCRIPTION OF PARTS AND DIMENSIONS

To reduce the hazard of getting the fingers caught, we recommend the assembly type as shown in Fig.5a and Fig.5b, where the wall and/or tubular frame act as a jamb and stop the door panel.

Alternatively, proceed as shown in Fig.6 overlapping the end of the wall (and/or closing upright) with the profile of the sliding panel and moderating the closing speed and speed of approach of the door.

✂ In some countries the laws forbid this type of assembly as there is a possible risk of getting the fingers caught.

Fig. 5a

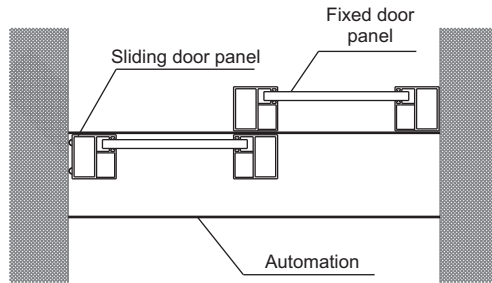


Fig. 5b

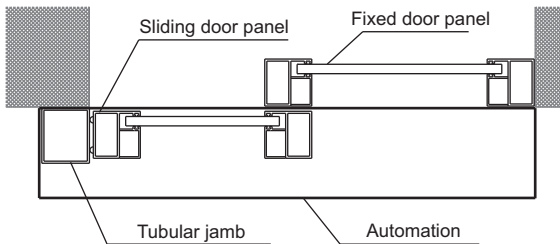


Fig. 6

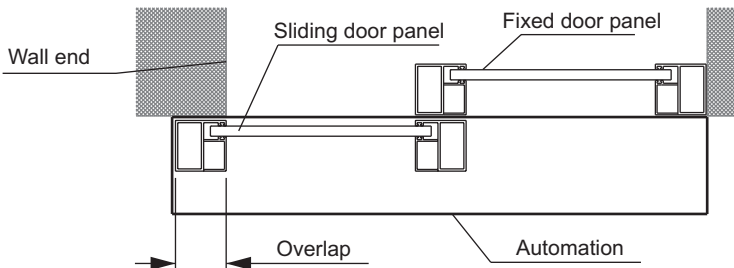
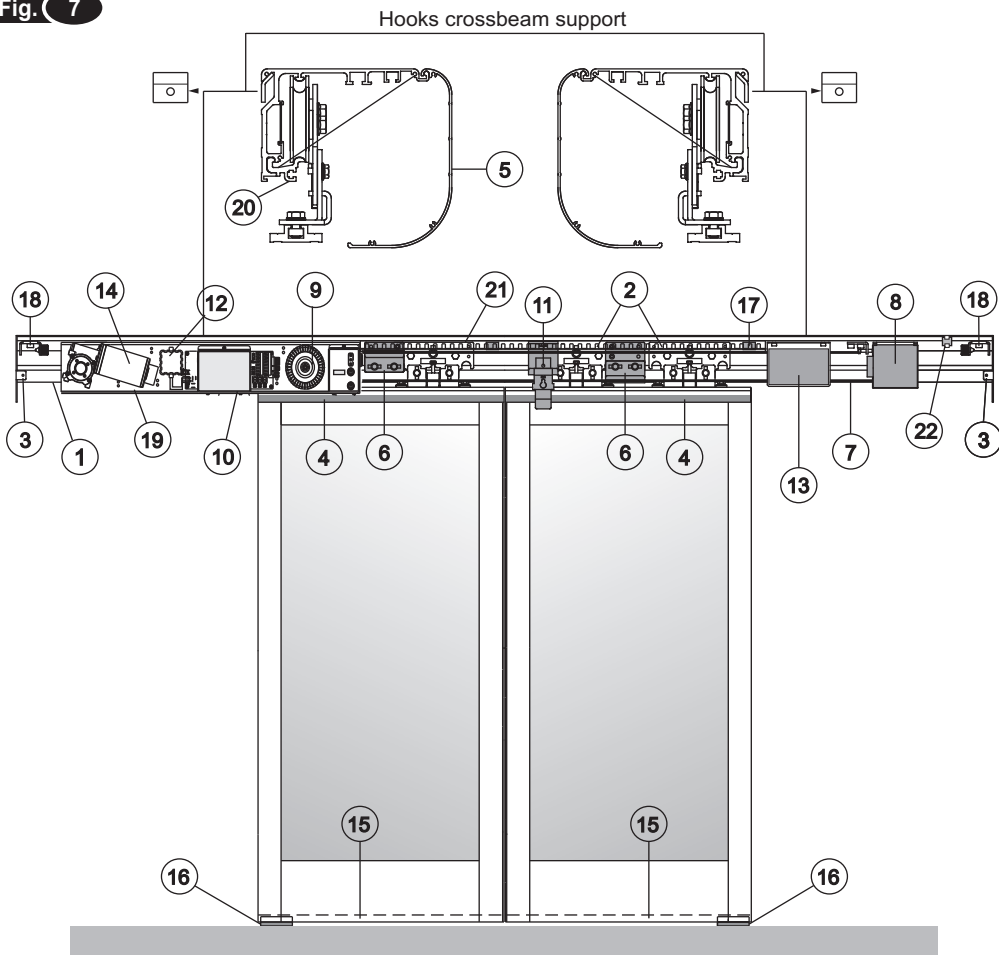


Fig. 7








- |   |                              |
|---|------------------------------|
| 1 - Main crossbar                             | 12 - Emergency battery       |
| 2 - Carriage with double wheel                | 13 - Photocell control unit  |
| 3 - Lateral case fastener                     | 14 - Gearmotor               |
| 4 - Adapter for door panel suspension         | 15 - Rail for door guide     |
| 5 - Casing                                    | 16 - Plastic runner on floor |
| 6 - Door panel drive bracket                  | 17 - Wire raceway            |
| 7 - Toothed transmission belt                 | 18 - Door stop               |
| 8 - Belt transmission with pulley and encoder | 19 - Metal motor module      |
| 9 - Low voltage transformer                   | 20 - Wheel glide profile     |
| 10 - Electronic control circuit               | 21 - Logline                 |
| 11 - Door lock with manual release            | 22 - Ferrite                 |



### 3.1 GENERAL RECOMMENDATIONS



The automation must be installed exclusively by competent, qualified technical personnel in possession of the technical requisites foreseen by the legislation in force in the country of installation.

-  Do not install the automation on the external wall of the building, subject to atmospheric agents (rain, snow, etc.).
-  Do not use the automation in environments with a potentially explosive atmosphere.
-  The zones in which there may be a danger of crushing, shearing, conveyance or other risks are signaled and protected by means of special electronic safety devices, safety stops or barriers. These devices must be installed depending on the environment and type of use and operating logic of the product.
-  The forces developed by the complete system during operation must respect the regulations in force in the country of installation; if this is not possible, protect and signal by means of electronic safety devices the zones affected by those forces.
-  Before installing the automation, verify that the structure to be automated is stable, sturdy and able to withstand the weight of the automation and, if necessary, take steps to ensure that it is. Topp spa is not liable for failure to comply with the rules of good workmanship in the construction of the door panels to motorize, or for any distortions that may develop with use of the device.

### 3.2 INSTALLING THE CROSSBAR

**(Model with two panels)** To install the crossbar, proceed as follows:

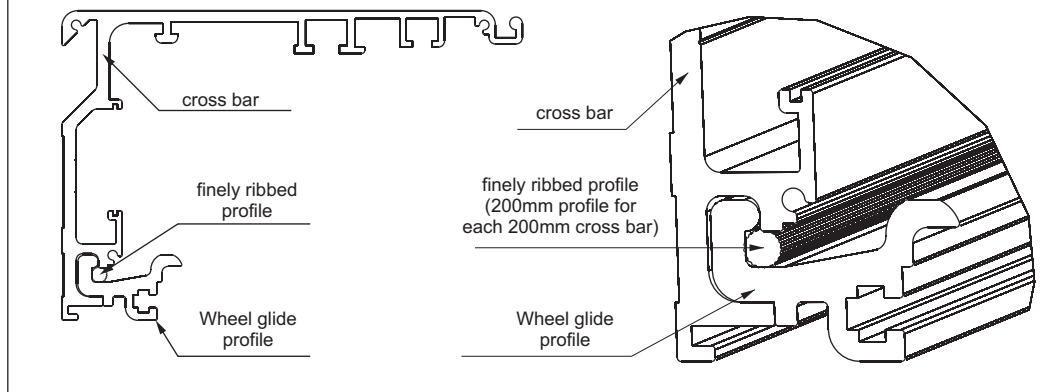
- Mark the surface where the automation will be fastened at the center of the opening VL that is also the center of the crossbar;
- Decide the position of fastening the crossbar supporting brackets, referring to the measurements shown in Fig.8;
  - ☞ If the floor is not perfectly flat, decide the position of the supporting brackets referring to the highest point of the floor.
- Fasten the crossbar supporting brackets to the wall using self-drilling/self-tapping screws type d5.5 or d6,3;
- Remove the cover on the casing;
- Install the crossbar and make sure it is aligned;
- Fasten the crossbar to the wall with 3 self-tapping screws type d6.3 for every meter of crossbar and paying careful attention not to damage the gliding base of the carriages with the drill spindle. In case of damage it will be necessary to replace the entire crossbar;
- After fastening the crossbar clean the glide zone soiled by drilling residues.

**((Model with 1 panel)** To install the crossbar, proceed as follows:

- Mark the surface where the automation will be fastened at the center of the crossbar that corresponds:
  - to the line of the wall end on the left of the doorway for application of 1 door panel with the opening toward the left;
  - to the line of the wall end on the left of the doorway for application of 1 door panel with the opening toward the right;
- Decide the position of fastening the crossbar supporting brackets, referring to the measurements shown in Fig.8;
  - ☞ If the floor is not perfectly flat, decide the position of the supporting brackets referring to the highest point of the floor.
- Remove the cover on the casing;
- Fasten the crossbar supporting brackets to the wall using self-drilling/self-tapping screws type d5.5 or d6,3.
- Install the crossbar and make sure it is aligned;
- Fasten the crossbar to the wall with 3 self-tapping screws type d6.3 for every meter of crossbar and paying careful attention not to damage the gliding base of the carriages with the drill spindle. In case of damage it will be necessary to replace the entire crossbar.
- After fastening the crossbar clean the glide zone soiled by drilling residues.
  - ☞ To install the wheel glide runner and finely ribbed profile on the crossbar, see Fig.10.

Materials of the fastening surface	Minimum thickness
IRON	2 mm (with lesser thickness use threaded rivets)
ALUMINUM	3 mm (with lesser thickness use threaded rivets)
REINFORCED CONCRETE	100 mm
SOLID WOOD	50 mm
PERFORATED CONCRETE	110 mm (with lesser thickness use chemical bolts)

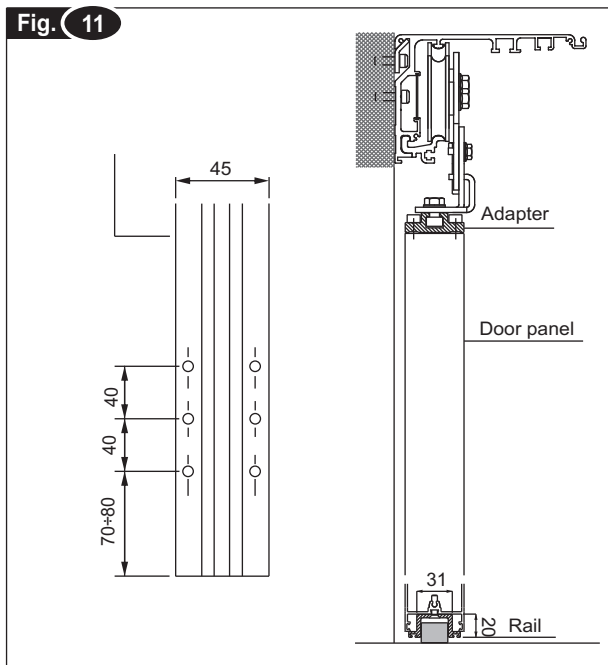
**Fig. 10**



### 3.3 INSTALLING THE ADAPTER AND RAIL

- Cut the adapter and rail to the measurement of the finished door width, removing another 2 mm from the jamb side;
- Make sure the upper part of the panel crossbar is reinforced at the base (minimum thickness 3 mm);
- Drill the adapter and rail starting at about 70/80 mm from the end;
- ✂ The number of fastening holes will depend on the size and weight of the door.
- Mark the fastening points on the door using the adapter and rail as a template;
- Drill the door panel at the top and fasten the adapter using cylindrical M6 screws or cylindrical self-tapping d5.5 screws depending on the type of material;
- Drill the door at the bottom and fasten the rail using flared self-tapping cylindrical screws diam. 4.8.

**Fig. 11**

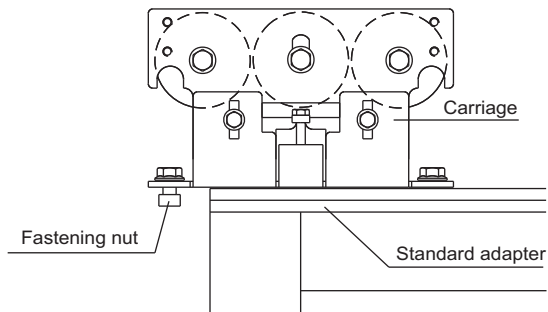


### 3.4 INSTALLING THE CARRIAGES ON THE DOOR

Install the carriages on the adapter as shown in the figure.

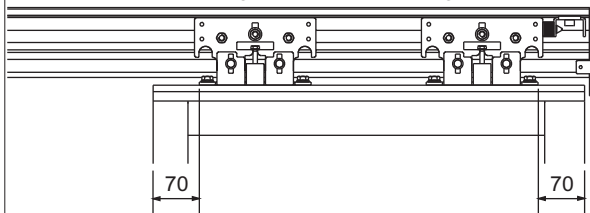
- ⚠ Make sure the carriages are installed correctly and are aligned with each other, with the adapter and with the crossbar.

**Fig. 12** Installation by insertion

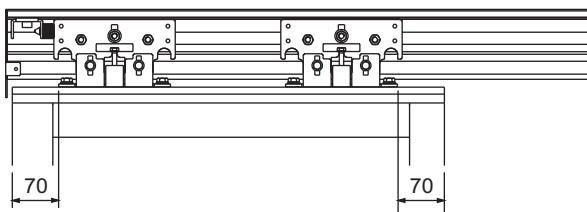


**Fig. 13**

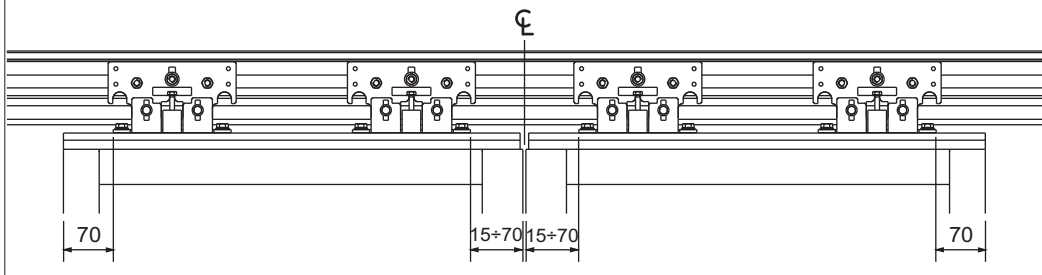
Single door panel, opening toward the left



Single door panel, opening toward the right



**Fig. 14** Double door panel, simultaneous opening toward the right and left



### 3.5 FASTENING AND ADJUSTMENT OF THE SLIDING PANELS

To fasten the sliding panels to the crossbar, proceed as follows:

- Lower the anti-derailing wheels of the carriages (Fig.15);
- Bring the panels to the crossbar and make sure the gliding base of the carriages is clean and free of any scraps;
- Fasten the door panel to the crossbar by raising it slightly and hooking it first on one side and then on the other, or both sides at once (Fig. 16);
- Loosen the fastening screws on the carriages and insert the no. 10 fixed wrench in the height adjustment screw on the carriage and turn it to the left or right so that the door panel is about 5 mm off the floor (height for the standard runner);
- Determine the distance "A" for adjustment of the door panel (Fig. 18);
  - ⊗ If an air seal brush must be installed between the sliding panel and the upright or wall, adjust the panel so that there is a space of about 1 mm between it and the brush along the entire length;
- Fasten the runner to the floor at point "A" using the anchor bolt and self-tapping screw d 6x70 contained in the hardware package (Fig.17).
- Adjust the distance "A" (Fig.18) by loosening the two screws that hold the lower bracket of the carriage to the adapter. The holes on the brackets are in slot form to permit movement of the door by about 18 mm.
- Before tightening the screws make sure the carriages are aligned with each other and with the crossbar.
- Adjust the height of the sliding panels (Fig.19) using the special adjustment screws on the carriages (Fig.18). After performing this operation, tighten the screws on the load-bearing wheels and raise the anti-derailing wheel.
  - ⊗ Using the height adjustment screws on the carriages you can raise or lower the door by  $\pm 10\text{mm}$  (with the crossbar installed on the basis of the measurements shown in Fig.8).

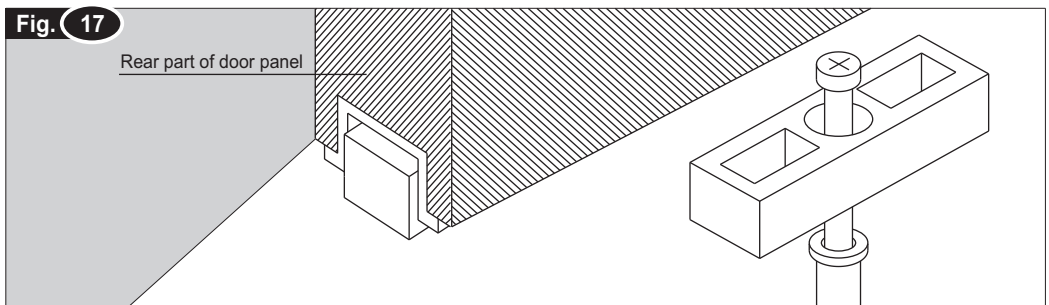
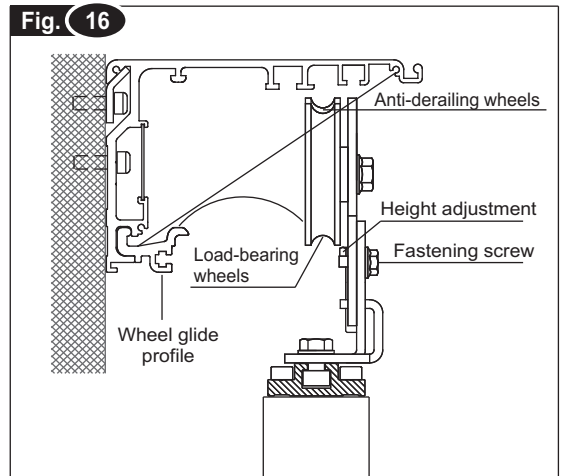
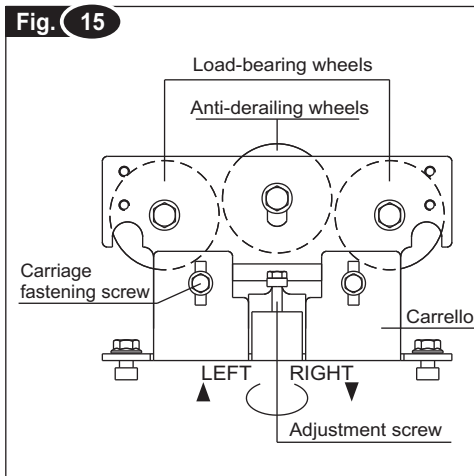


Fig. 18

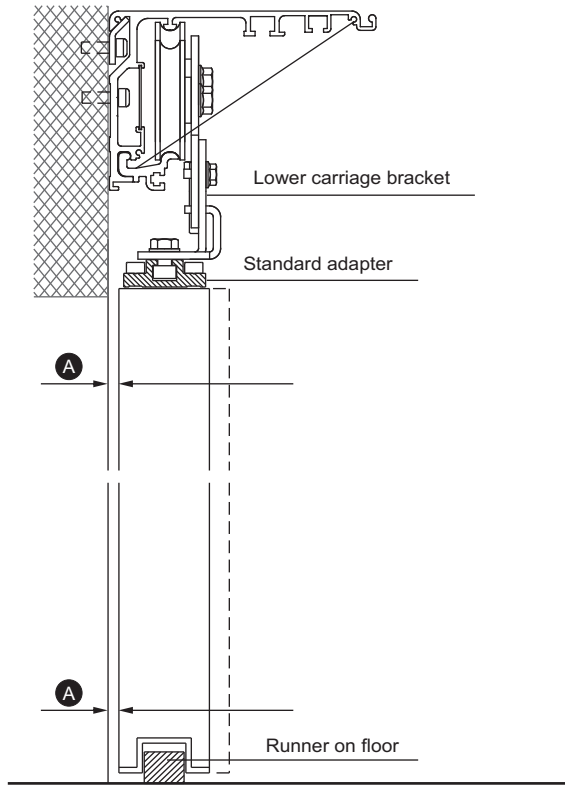
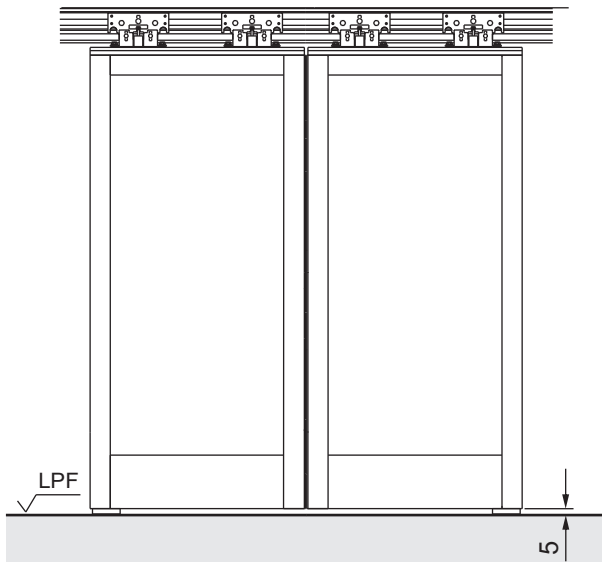


Fig. 19



### 3.6 INSTALLING THE MOTOR MODULE, BELT TRANSMISSION, BELT, LOGLINE

#### K240 - model with 2 door panels (Fig.20a)

VPA	A	B	L Belt	L Logline
1000	916	916	2 x 1816	987
1100	968	968	2 x 1920	1091
1200	1020	1020	2 x 2024	1195
1300	1072	1072	2 x 2128	1299
1400	1124	1124	2 x 2232	1403
1500	1176	1176	2 x 2336	1507
1600	1228	1228	2 x 2440	1611
1700	1280	1280	2 x 2544	1715
1800	1332	1332	2 x 2648	1819
1900	1384	1384	2 x 2752	1923
2000	1436	1436	2 x 2856	2027
2100	1488	1488	2 x 2960	2131
2200	1540	1540	2 x 3064	2235
2300	1592	1592	2 x 3168	2339
2400	1644	1644	2 x 3272	2443
2500	1696	1696	2 x 3376	2547
2600	1748	1748	2 x 3480	2651
2700	1800	1800	2 x 3584	2755
2800	1852	1852	2 x 3688	2859
2900	1904	1904	2 x 3792	2963
3000	1956	1956	2 x 3896	3067
3100	2008	2008	2 x 4000	3171
3200	2060	2060	2 x 4104	3275

#### K240 - model with 1 door panel (Fig.20b)

VPA	A	B	L Belt	L Logline
800	160	1058	1 x 2104	213
900	160	1162	1 x 2312	317
1000	160	1266	1 x 2520	421
1100	160	1370	1 x 2728	525
1200	160	1474	1 x 2936	629
1300	160	1578	1 x 3144	733
1400	160	1682	1 x 3352	837
1500	160	1786	1 x 3560	941
1600	160	1890	1 x 3768	1045
1700	160	1994	1 x 3976	1149
1800	160	2098	1 x 4184	1253
1900	160	2202	1 x 4392	1357
2000	160	2306	1 x 4600	1461
2100	160	2410	1 x 4808	1565
2200	160	2514	1 x 5016	1669
2300	160	2618	1 x 5224	1773
2400	160	2722	1 x 5432	1877
2500	160	2826	1 x 5640	1981
2600	160	2930	1 x 5848	2085
2700	160	3034	1 x 6056	2189
2800	160	3138	1 x 6264	2293
2900	160	3242	1 x 6472	2397
3000	160	3346	1 x 6680	2501
3100	160	3450	1 x 6888	2605
3200	160	3554	1 x 7096	2709

Fig. 20a

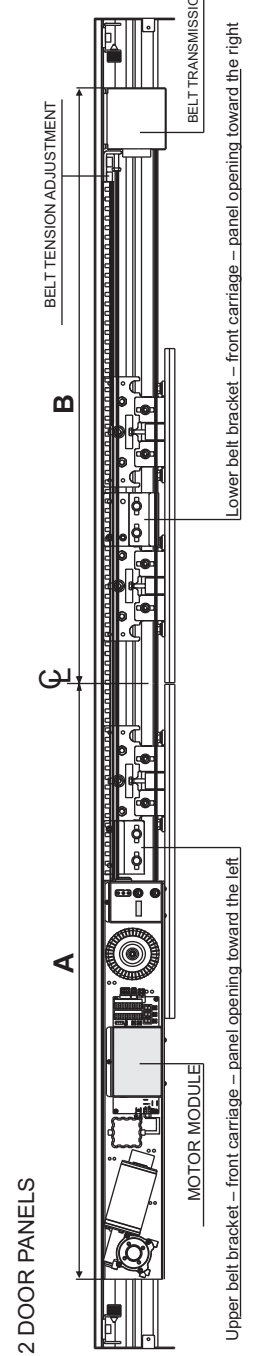
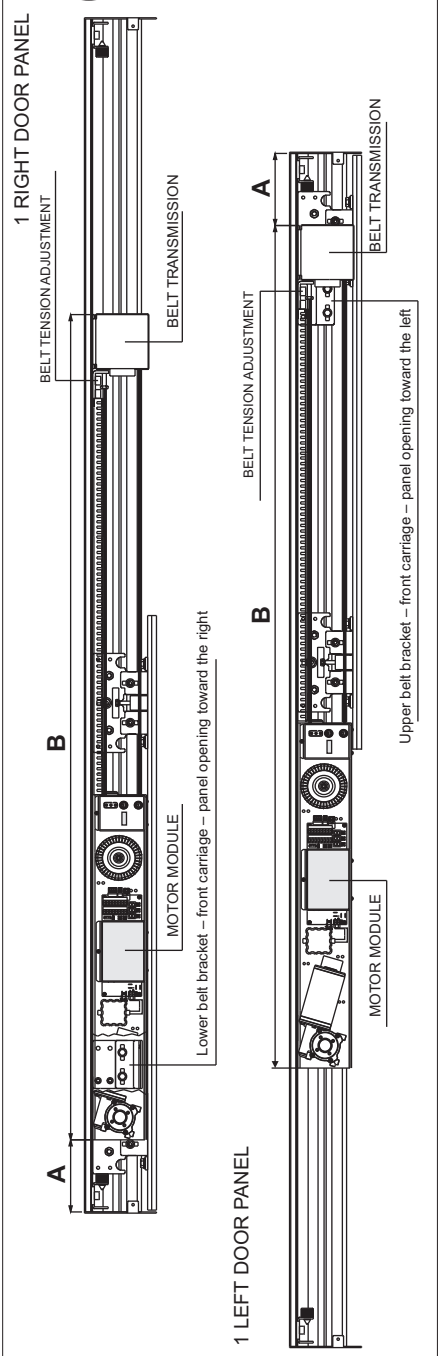


Fig. 20b



Before installing the motor module, belt transmission and belt on the crossbar, prepare and install the wires necessary for the electrical connections and make sure the carriages, door panels and runners on the floor have been fully adjusted and positioned.

**Installing the motor module (Fig.21):**

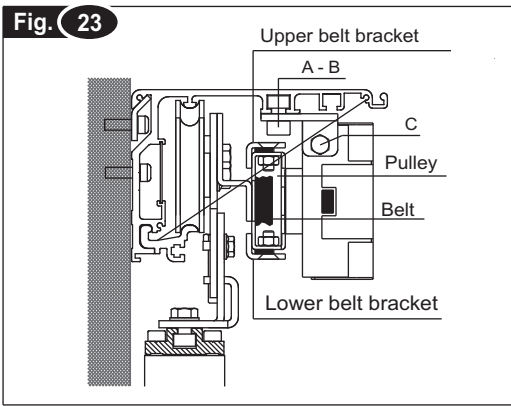
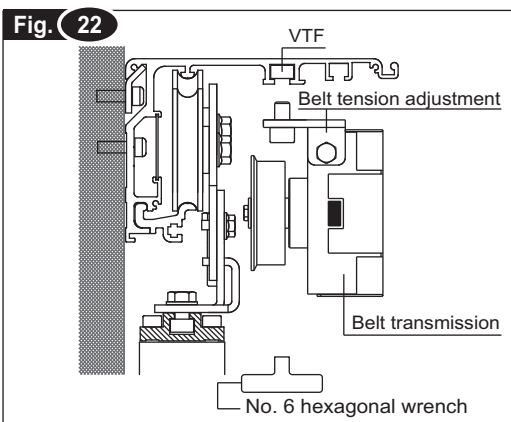
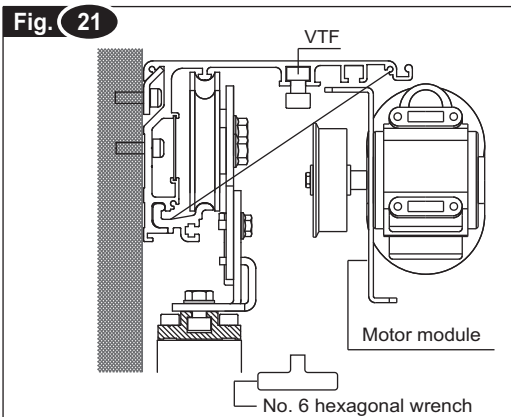
- Mark the reference measurements on the crossbar using the tables on page 16;
- Loosen the two VTF screws on the crossbar for fastening the motor module;
- Fit the motor module with the slots provided for fastening in the VTF screws, check the reference mark on the crossbar once more and tighten the VTF screws.

**Installing the belt transmission (Fig.22):**

- Mark the reference measurements on the crossbar using the tables on page 16;
- Remove the two VTF screws on the crossbar for fastening the belt transmission;
- Fit the transmission with the specific fastening holes in the VTF screws and tighten them;
- Adjust the position of the belt tension adjustment on the crossbar.

**Installing the transmission belt (Fig.23):**

- Install the transmission belt on the motor and transmission pulley making sure the belt junction brackets are positioned as shown in Fig.23. (Upper bracket for door opening to the left, lower bracket for door opening to the right).
- Slightly loosen screws "A" on the tension adjustment, take the belt transmission to the end of its run and tighten screws "A".
- To tighten the belt, loosen screws "B" on the transmission and turn screw "C" to obtain the proper belt tension. To check the tension, with the handshake bring the two edges of the belt as shown in Figure 23a. The tension is enough if there is some resistance before the contact of the two edges.
- Tighten screws "B" after checking that the transmission is aligned with the crossbar.



**Fig. 23a**

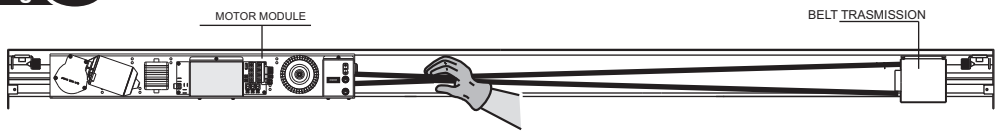
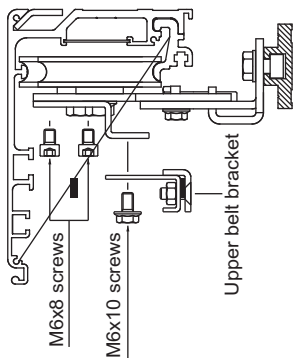
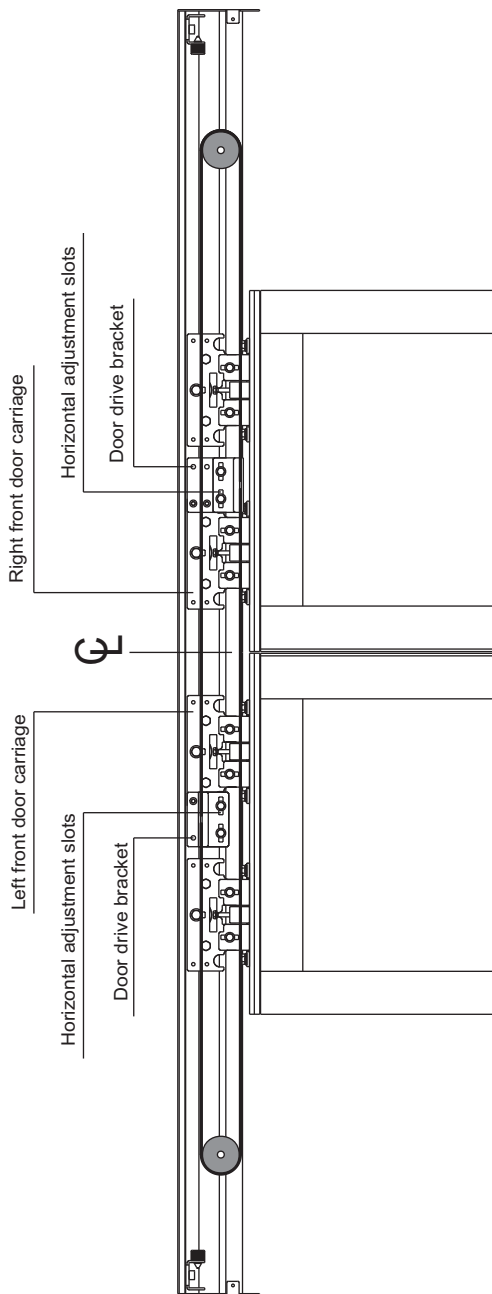
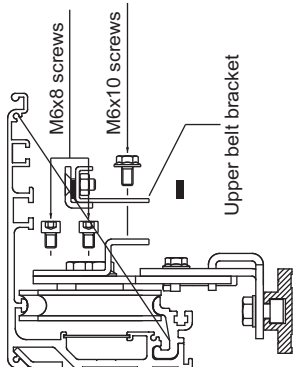


Fig. 24 2 DOORS – simultaneous opening toward the right and left

DOOR OPENING TO RIGHT



DOOR OPENING TO LEFT









**REV 01.09**  
*detach and give to the user*

### 1 GENERAL RECOMMENDATIONS

Installation, electrical connection and routine/special maintenance of the automation must be done exclusively by qualified technical personnel in possession of the professional requisites foreseen by the laws in the country of installation.

The user must not open the casing or perform any operations restricted to maintenance personnel or specialized experts, even to change the programming parameters and adjustment of the automation.

In case of breakdown or malfunction of the door, the user should simply switch off the circuit breaker and abstain, manually block the doors and contact the installer.

The user must be able to control the automation using the devices provided for that purpose (key switch, knob switch, digital switch) without creating situations of hazard through careless or improper use of the automation such as trying to control it when people, objects or animals are within its radius of action.

To ensure correct operation, the automation required regular maintenance, the timing and frequency of which should be agreed on with the installer. For normal use, TOPP recommends maintenance every six months.

At the end of its working life, the automation must be demolished by qualified personnel in respect of the legislation in force on the subject of environmental safeguards.

Do not remove or alter the plates and labels applied by the manufacturer on the automation and its accessories.

This device is not suitable for use by persons (including children) with reduced sensorial or mental capacity or insufficient expertise, unless they are supervised and instructed in proper use by persons responsible for their safety. Children must be controlled and prevented from playing or standing in the radius of action of the door.

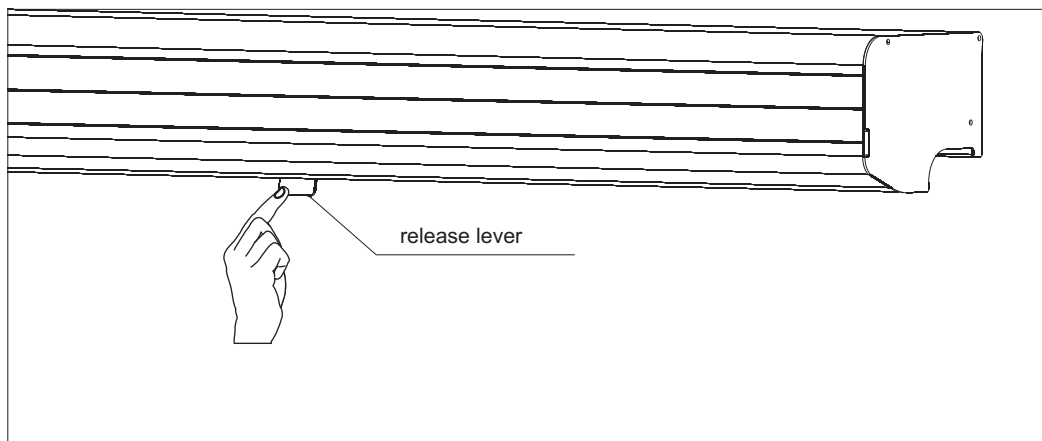
### 2 KEY SWITCH

When you wish to open the door from the outside, turn the key of the key switch KC1 for at least 1 second. The door opens automatically to allow entry, then closes and resumes its previous state of operation.



### 3 MANUAL RELEASE OF THE DOORS

In case of power outage, to release and open the door push frontally on the manual release lever located under the casing and, at the same time, pull the door by hand until it opens.



### 4 PROGRAM SELECTION WITH KNOB

The program selection knob mod. MS1 serves to select different operating modes of the door using a knob. The program selected is signaled by lighting the respective LED.

The following is a description of the functions that can be programmed:



**CLOSED** - The door closes automatically from whatever position it is in, all the sensors are disabled and the door block is on.



**ENTER ONLY** - The internal exit sensor is disabled, the external entry sensor is enabled and the door block is on.



**EXIT ONLY** - The external entry sensor is disabled, the internal exit sensor is enabled and the door block is on.



**TOTAL ENTRY/EXIT** - The external/internal sensors are disabled, the door block is off and the automatic opening of the door is total.



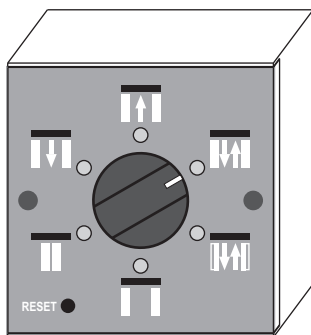
**PARTIAL ENTRY/EXIT** - The external/internal sensors are enabled, the door block is off and the automatic opening of the door is reduced.



**OPEN** - The door opens automatically from whatever position it is in, and remains blocked with the door open.



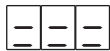
**RESET** - Resets the electronic control circuit and switch.



The program selection knob mod. MS1 serves to select different operating modes of the door using a knob. The program selected is signaled by lighting the respective LED



To block operation of the keys hold **P1** down for about 4 seconds. When the three vertical bars appear, release the key.



To release operation of the keys hold **P1** down for about 4 seconds. When the three horizontal bars appear, release it



Vertical bar symbols = keys released



Horizontal bar symbols = keys blocked

To set the door functions press **P2** or **P3**.

To open the door in case of need press and release **P1**.



**CLOSED** - The door closes automatically from whatever position it is in, all the sensors are disabled and the door block is on.



**ENTER ONLY** - The internal exit sensor is disabled, the external entry sensor is enabled and the door block is on.



**EXIT ONLY** - The external entry sensor is disabled, the internal exit sensor is enabled and the door block is on.



**TOTAL ENTRY/EXIT** - The external/internal sensors are disabled, the door block is off and the automatic opening of the door is total.

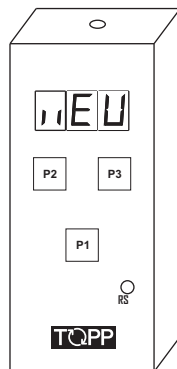


**PARTIAL ENTRY/EXIT** - The external/internal sensors are enabled, the door block is off and the automatic opening of the door is reduced.



**OPEN** - The door opens automatically from whatever position it is in, and remains blocked with the door open.

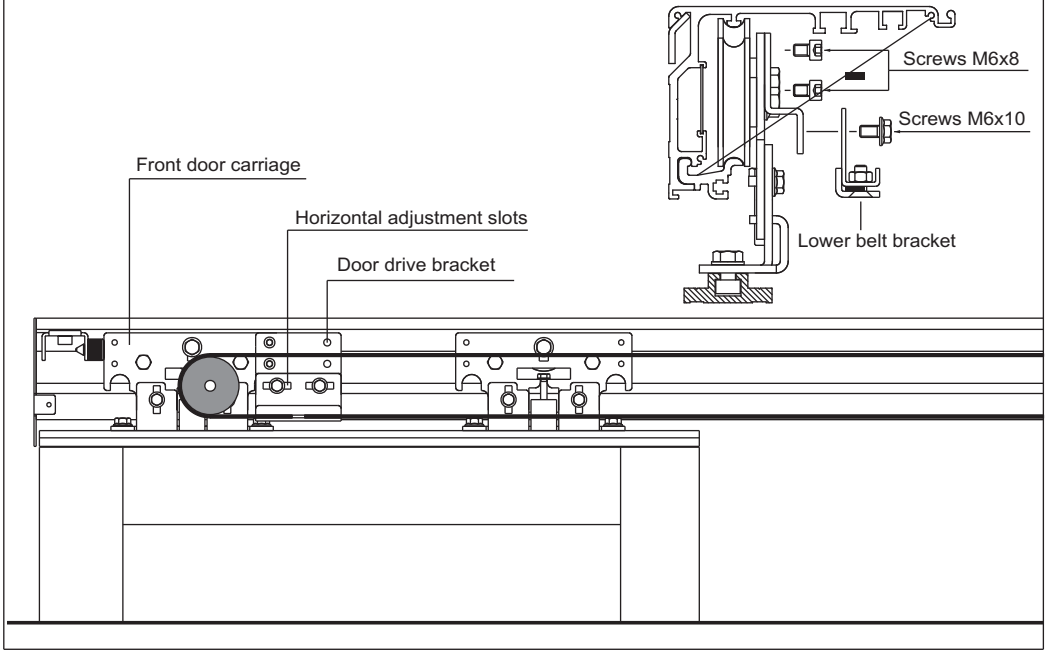
**RESET** - Resets the electronic control circuit and switch.



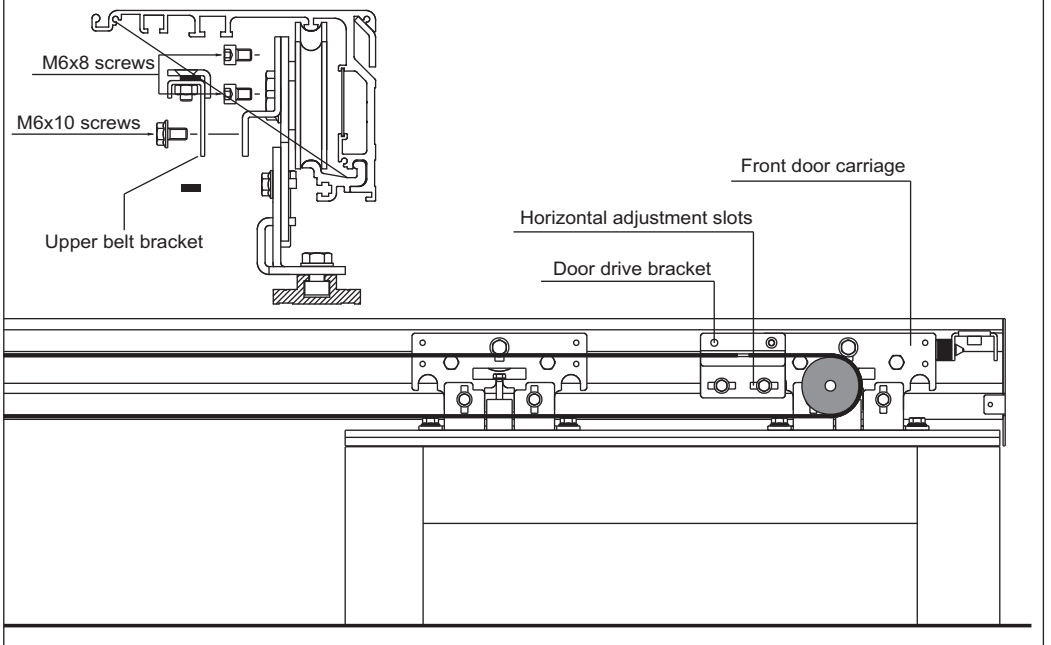


TOPP SPA  
Via Galvani, 59 - 36066 Sandrigo (VI) - Italia  
Tel. +39 0444 656700 - Fax +39 0444 656701  
Info@topp.it - www.topp.it

**Fig. 25** 1 RIGHT DOOR – opening toward the right



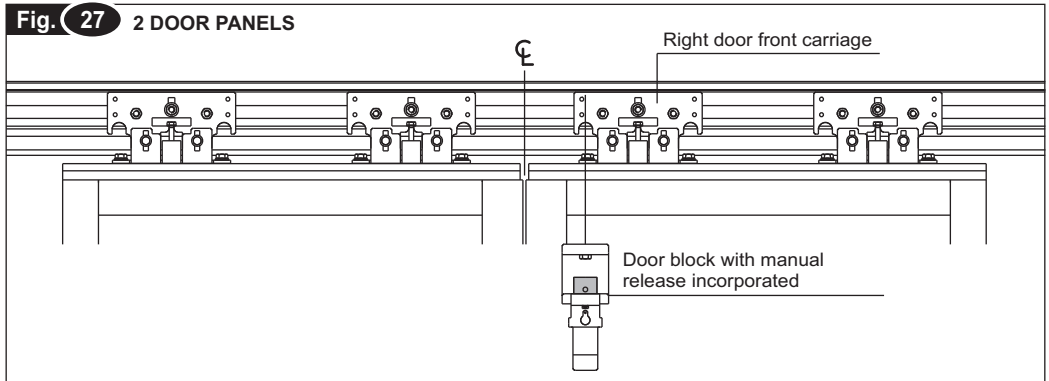
**Fig. 26** 1 LEFT DOOR – opening toward the left



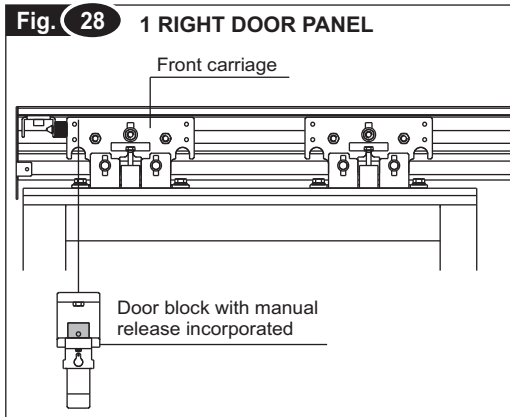
### 3.8 INSTALLING THE DOOR BLOCK

During installation, make sure that when the door is closed with the block on, it must be possible to open the door manually by at least 2-3 mm. This tolerance is necessary to enable the block to be released without difficulty.

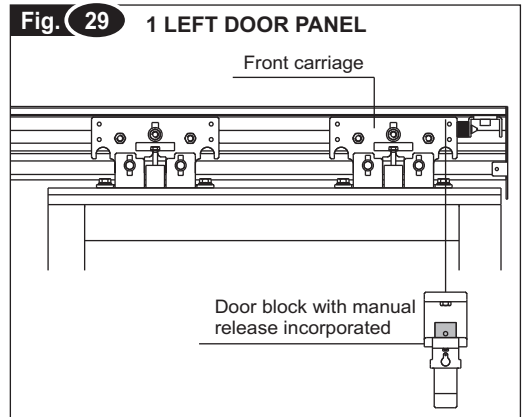
**Fig. 27** 2 DOOR PANELS



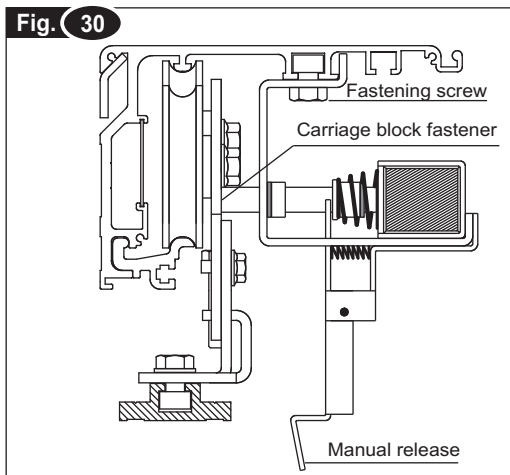
**Fig. 28** 1 RIGHT DOOR PANEL



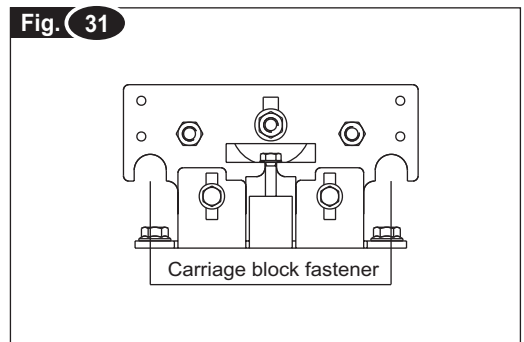
**Fig. 29** 1 LEFT DOOR PANEL



**Fig. 30**



**Fig. 31**



To release and open the door, push the manual release lever under the casing forward and, at the same time, pull the door with your hand until it opens.

### 3.9 INSTALLING THE CASING

Fasten the lateral caps on the beam using 3 screws type TSP d3.5x9.5 for each cap, supplied in the hardware package.

Apply an antivibration felt strip every 300mm along the beam (**Fig.32 Ref.1**).

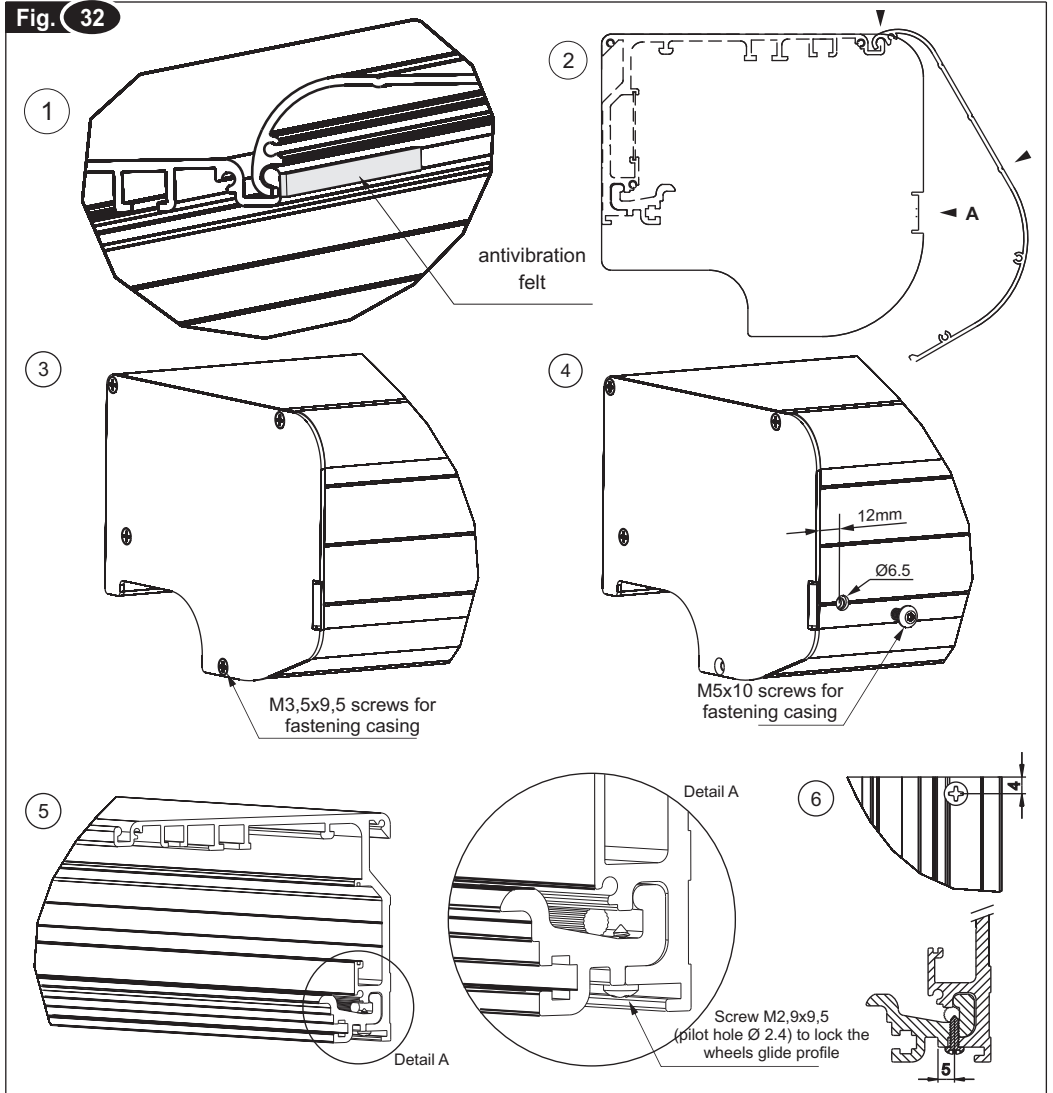
Fit the upper part of the casing in its housing on top of the beam, holding it in a tilted position at a 30° angle and insert it until it is flush (**Fig.32 Ref.2**).

Fasten the casing to the beam using two more screws type TSP d3.5x9.5 (**Fig.32 Ref.3**).

If it should not be possible to fasten the casing from the side, proceed as follows:

- Drill symmetrical holes in the casing cover using a suitable drill with a  $\text{Ø}6.5$  bit for aluminum, with the measurements and position indicated in **Fig.32 Ref.4**
- Fasten the casing to the beam using the two screws type TCEI M5x10.

In case the side caps were not mounted, it would be convenient to screw no. 2 AF TC screws 2.9x9.5 at the beam ends (perform a pilot hole  $\text{Ø}2.4$ ), as shown in **fig. 32, ref. 5-6**, to lock the wheels glide profile.



### 4.1 GENERAL RECOMMENDATIONS



Electrical connection of the automation must be made exclusively by qualified technical personnel in possession of the professional requisites foreseen by the laws in the country of installation, who must issue the client a certificate of conformity of the connection and/or installation made.

Whatever type of electrical material is used for connection (plug, cord, terminals, etc.), it must be suitable for the use, with the "CE" seal of approval and must comply with the requisites foreseen by the laws in force in the country of installation. For the wiring, use cables with double insulation up to the immediate vicinity of the connectors.

The electrical power line to which the control unit is connected must comply with the requisites foreseen by the laws in force in the country of installation, and must comply with the technical requisites listed in table 1 and on the "CE" rating plate (par. 3.1).

The mains to which the device will be connected must be equipped with a safety circuit breaker with contact opening of at least 3mm. These devices must be installed in the power system in conformity with the requisites foreseen by the legislation in force in the country of installation.

During installation, the metal guard on the power supply filter must not be removed for any reason. The manufacturer is not liable for any damage to persons or property in case of failure to comply with this recommendation.

The installation must include a ground wire longer than the power cord so that, in case of traction, the ground wire is the last to stretch.

We recommend the following types of power cables: H05VV-F 3X0.75, H05RR-F 3X0.75, H05RN-F 3X0.75. For the analogue switch cable we recommend using a multipole 7 x 0.5 cable type LI-YY, and for the digital switch 4x0.5 LI-YY.

Before making electrical connection of the automation, make sure the power cord has not been damaged.

The hole drilled on the profile for passage of the power cord must be made without any rough or sharp edges or sharp corners that could damage the wire.

### 4.2 ELECTRICAL CONNECTION

- Before fastening the door to the wall, drill a hole on the bottom of the crossbar (or more than one if you need to connect accessories) where the power cables emerge from the wall. The holes should be 10 mm in diameter, fitted with the rubber cable sleeves supplied.

- If the raceway has not already been installed, cut it to size in accordance with the tables in paragraph 3.6 and fasten it to the crossbar using the screws and nuts supplied, as shown in figure 1. The spacing between nut and nut should be 400 mm.

- Make sure there is a switch with a contact opening of at least 3 mm between the automation and the mains, for omnipolar disconnection of power.

- Thread the power cable through the cable sleeve as shown in figure 2.

- Run the cable to the right along the groove in the crossbar, using the plates supplied to hold the wires in place.

- Near the right end of the stroke, pass the power cable through the ferrite twice, forming a coil (see figure 3: double passage of the cable through the ferrite). If there are also accessory cables, provide the necessary number of ferrites

and repeat the operation as for the power cable.

- Make sure the cables are securely fastened, possibly using special clamps to keep them in order.

- Pass the cables in the front section over the belt/encoder transmission, using the groove on the crossbar, and inside the special raceway.

- Take the protective cap off the power filter box (see fig. 34), drill a hole in it for passage of the cable, remove the

least part of the outer sheath sufficient for installation, taking care to leave the ground wire (yellow-green wire) longer than the other wires so that, after fastening the cable to the terminal board and replacing the cap on the box, only the double insulated cable is accessible.

- Connect the cables of any accessories as described in the appropriate figures (see from fig. 35 to fig. 40)

- Close the raceway, making sure all the cables are inside it.

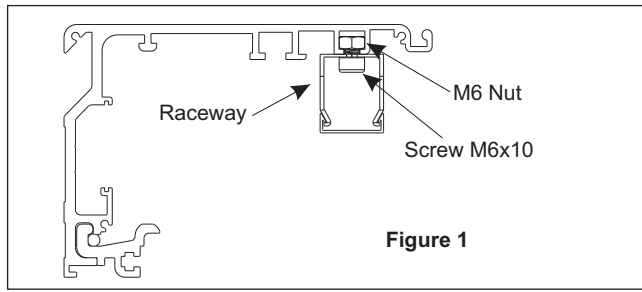


Figure 1

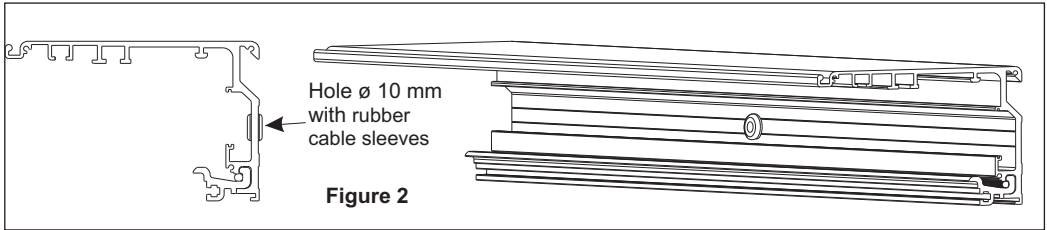


Figure 2

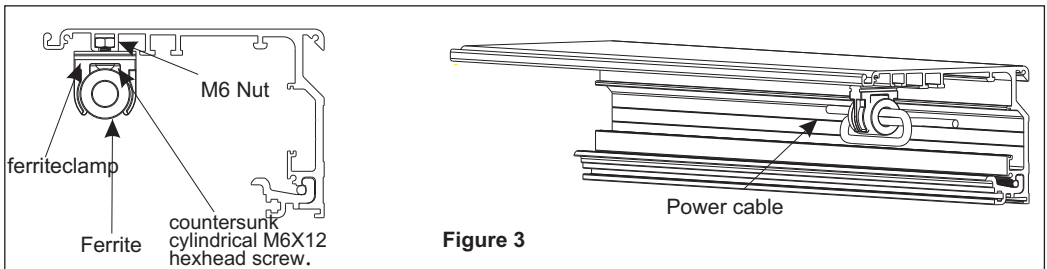
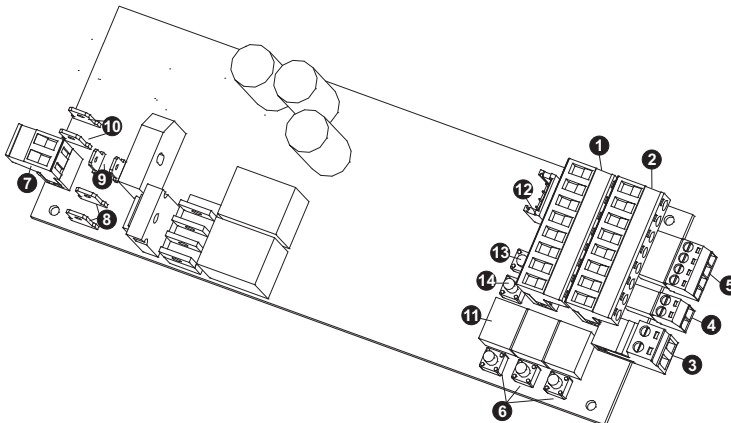


Figure 3

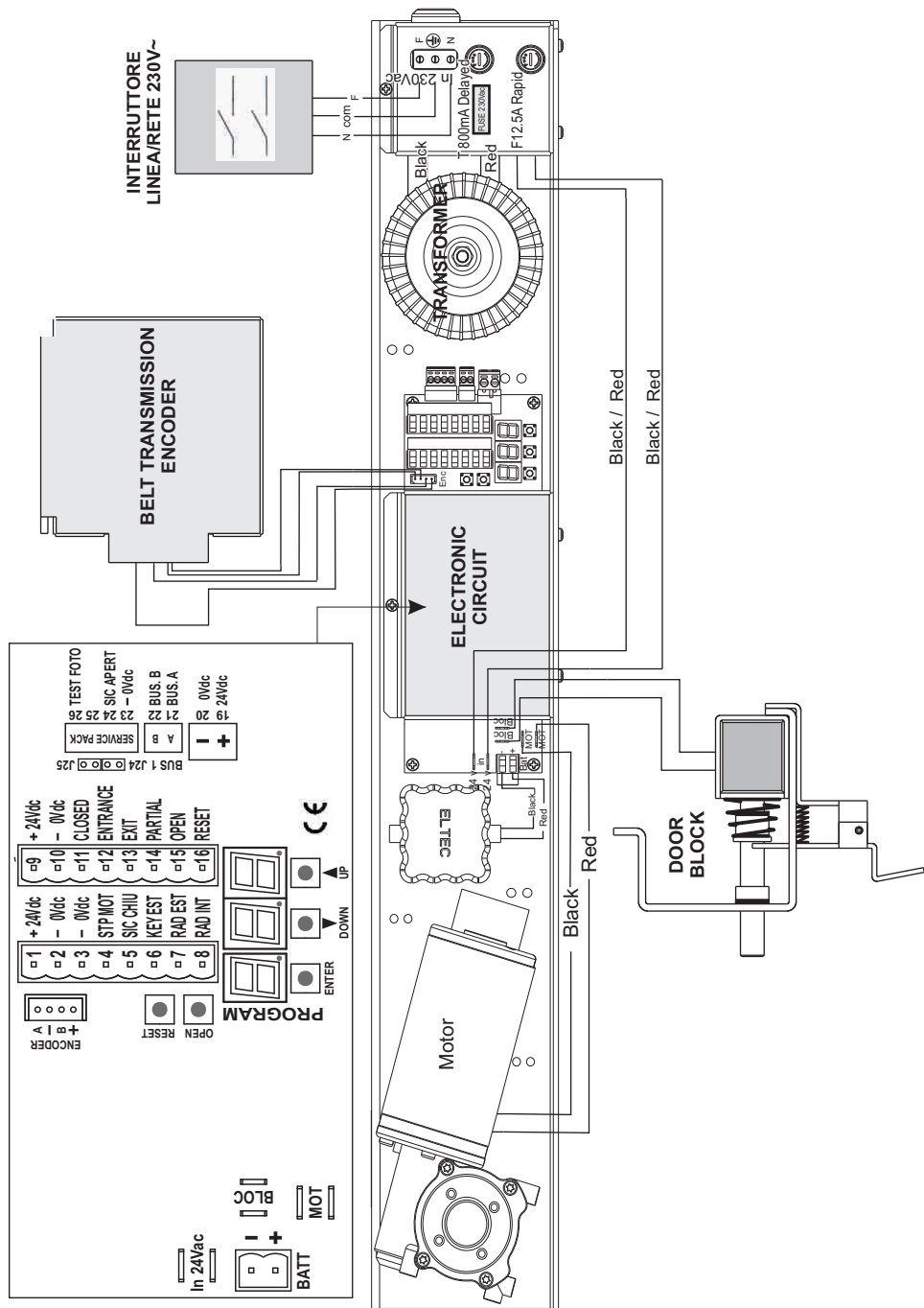
### 4.3 ELECTRONIC CIRCUIT BOARD

Fig. 33



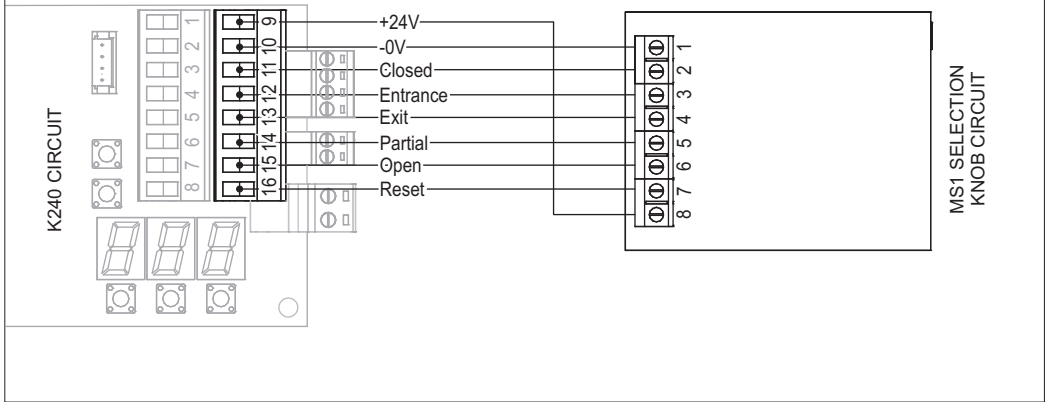
1. Infrared sensors, microwave sensors, photocells, key devices and emergency key input
2. Program selection knob input
3. Digital power switch input
4. Digital switch input
5. Safety opening and photocell test input
6. Function programming keys
7. Emergency battery system input
8. Gearmotor input
9. Door block input
10. Transformer input
11. Luminous display
12. Encoder wire input
13. OPEN Key
14. RESET key

Fig. 34



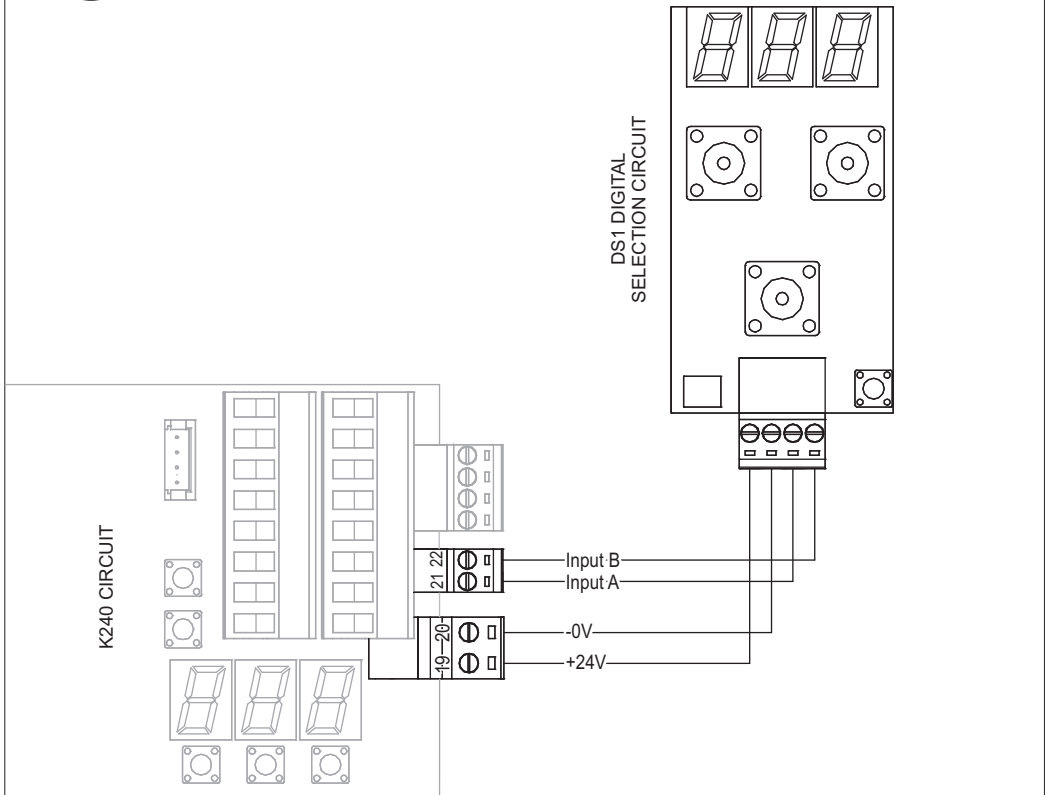
## 4.5 PROGRAM SELECTION WITH MS1 KNOB

Fig. 35



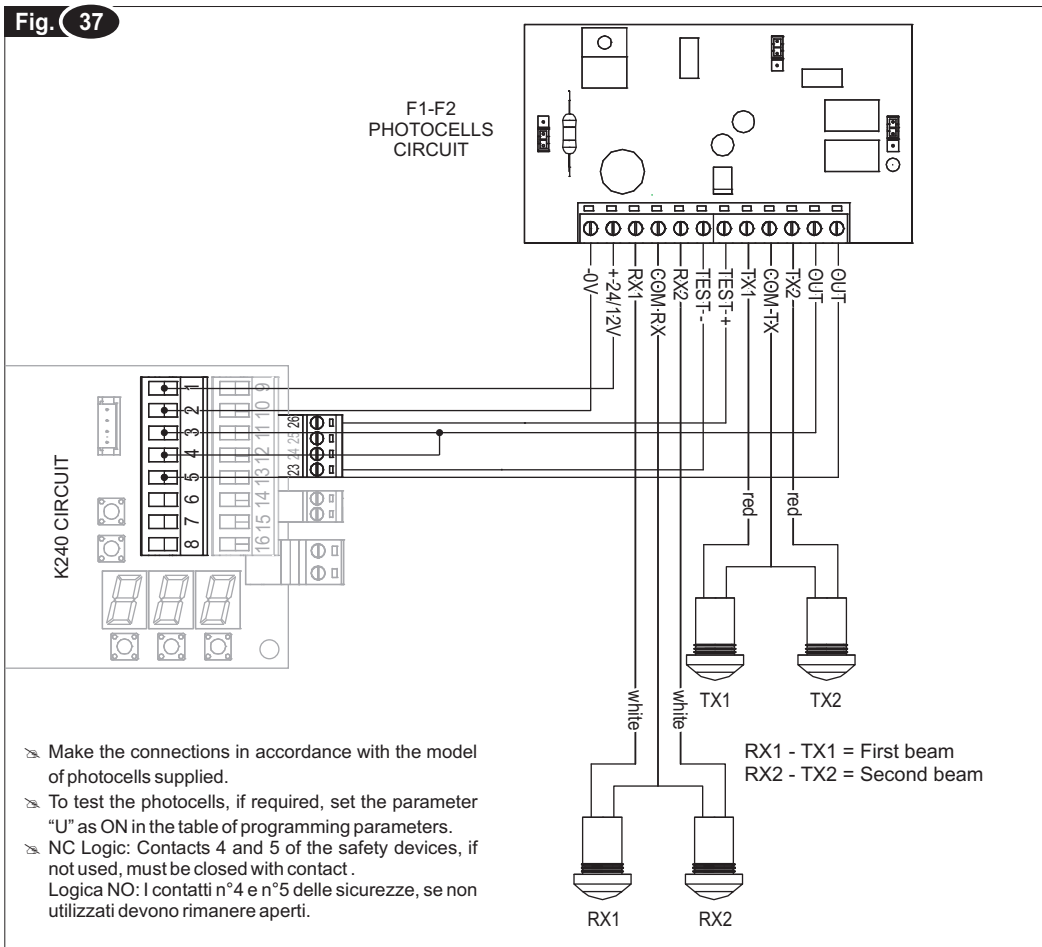
## 4.6 DS1 DIGITAL CONNECTION

Fig. 36



## 4.7 SINGLE (F1) AND DOUBLE (F2) BEAM PHOTOCELLS

Fig. 37



## 4.8 KEY DEVICE CONNECTION

Fig. 38

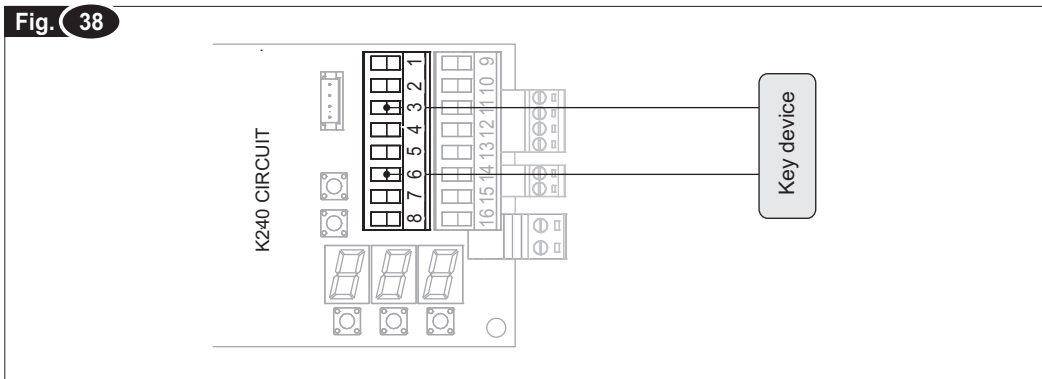


Fig. 39

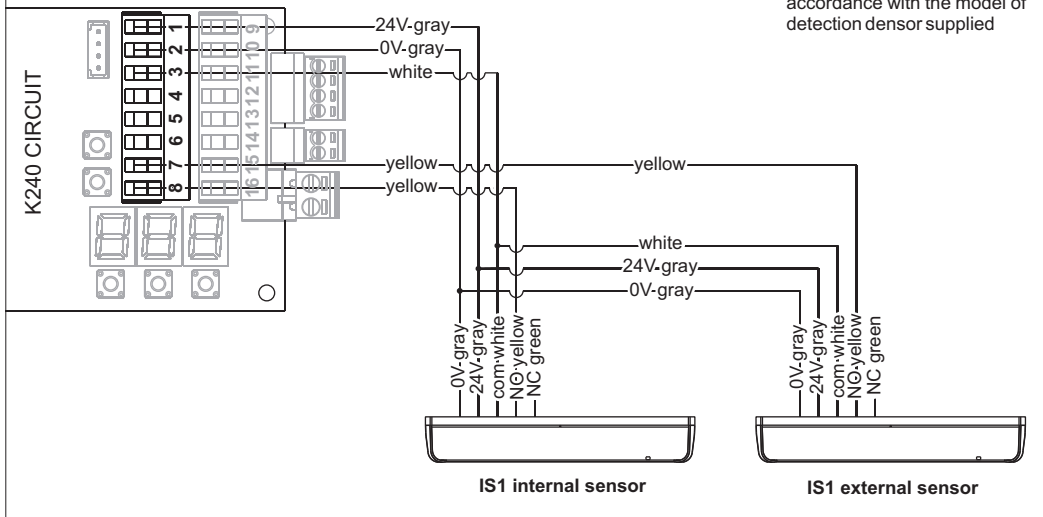


Fig. 39a

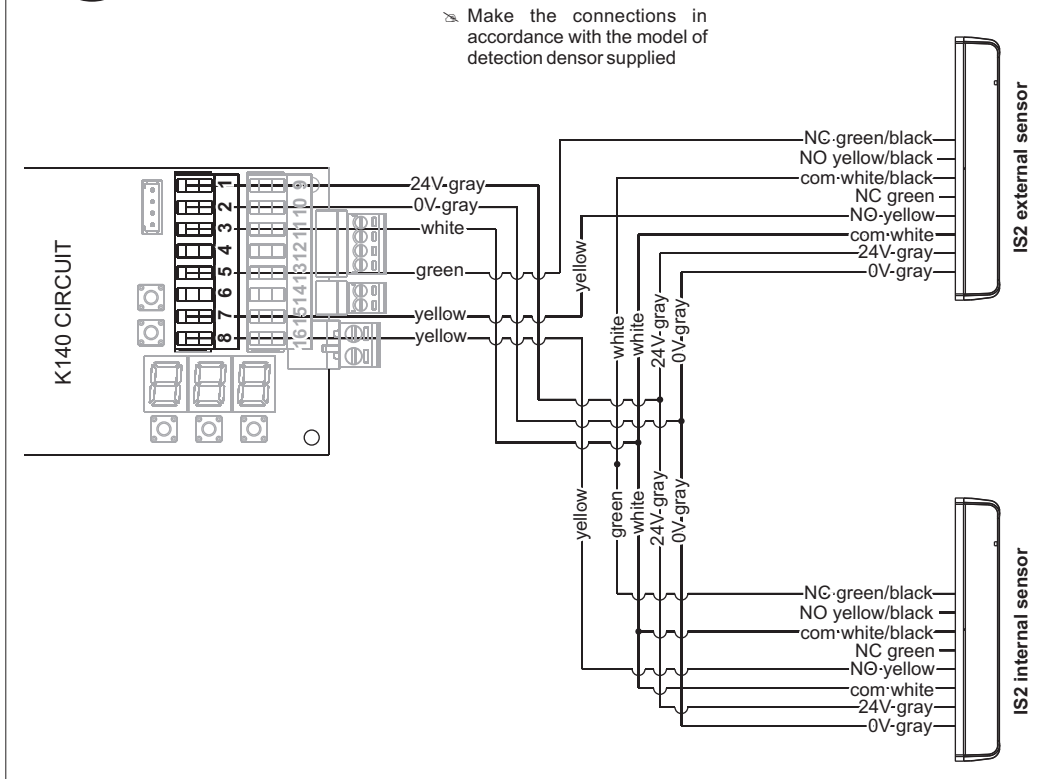
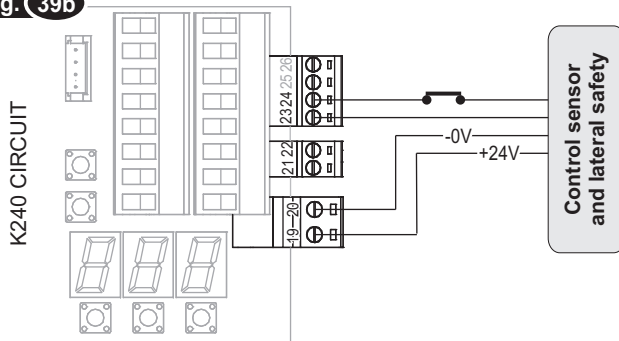
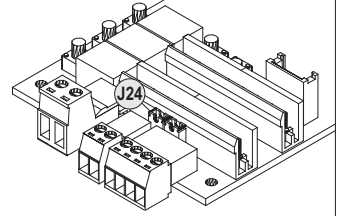


Fig. 39b

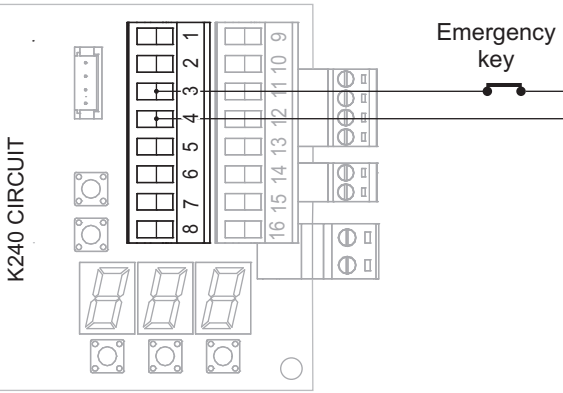


Remove jumper J24 if contacts 23 and 24 of the lateral safety are used



#### 4.10 EMERGENCY KEY CONNECTION

Fig. 40



**5.1 TECHNICAL DESCRIPTION**

The automation is electromechanical, without clutch or brakes, to prevent possible blockage of a continuous nature due to damages or breakage of the structure.

The power supply is 230V~ 50/60 Hz with low voltage transformer 24V - 100 W.

The main section bar/crossbar of the automation is made of high resistance anodized extruded aluminum. The gearmotor, toothed belt and electronic control circuit are incorporated in a covered casing in anodized extruded aluminum, fastened by fitting for more rapid, simple access in case of maintenance.

The carriages supporting the door are made of sheet steel, and are equipped with high-density plastic wheels with lifetime lubrication of the bearings, on a rail inside the main section bar/crossbar. The transmission and movement via gearmotor function at 24V 45W on a wormscrew with lifetime lubrication and a toothed belt in anti-static rubber material with steel cable strands that are long-lasting and wear-resistant.

The electronic control circuit is a microprocessor type with keys for adjustment of the parameters such as speed of opening and closure, slowing space, low approach speed, automatic reclosing time and mode of operation.

The movement, position and speed of the door are managed by the electronic control circuit via a reading device and optical encoder installed on the gearmotor or belt transmission.

Safety anti-crushing device on both closure and opening, that enables the door to reverse its movement if it meets an obstacle.

**5.2 EMERGENCY BATTERY**

**Automatic emergency opening or closure:** The automation is equipped with a rechargeable emergency battery that, in case of power outage on the 230V mains, automatically opens or closes the doors. After performing the maneuver, the doors remain in this position until power is restored on the mains at 230V.

The automation will resume functioning in accordance with the program setting by the selection knob, after power has been restored. Emergency opening or closure depends on the function entered in the program setting of the electronic circuit board.

**Supervision and automatic testing of the emergency battery:** The emergency battery function is kept under constant control by the electronic microprocessor control circuit. This supervision and test constantly verifies the efficiency of the battery that, in case of malfunction, blocks the door open and thereby signals the malfunction. Emergency opening or closure depends on the function entered in the program setting of the electronic circuit board.

**Manual emergency opening:** When it is required that the emergency opening not be performed automatically in case of power outage on the 230V mains, it is possible to install a key for management of this function.

When the key is installed, the emergency battery will not act in case of power outage, until the key is pressed. The key must be one of the locking kind. To use this function, the program setting of parameter [S] on CH and connect the key to contacts 3 and 6 of the electronic circuit board.

**Emergency manual opening/closure with program selection knob:** If necessary, in case of power outage, the door can be opened or closed using the program selection switch. Switch to "OPEN" to open the door and "CLOSE" to close it. To use this function, the program parameter setting on the electronic circuit board should be [S] on AP and [t] on E1.

**5.3 RESET PROCEDURE**

Power the automation using the switch installed between the door and the mains. When switched on, the monitor screen displays, in sequence, the model of door installed (in this case 140) and the software version of the circuit board; the third value, multiplied by 10000, indicates the number of cycles performed by the automation.

The automation then performs a procedure for memorization of the run and acquisition of the weight and friction called the reset procedure. During this procedure, the door opens, at slow speed, as far as the jamb, and performs a partial closure, then reverses direction to the fully open position; after a few seconds it closes to the jamb and the monitor displays EU to indicate the end of the reset procedure.

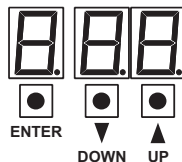
With the switch set on "CLOSED" and/or with the photocell input on, the reset procedure is interrupted. It can be performed again, however, by pressing the reset key on its electronic circuit board or that of the peripheral device installed.

## 5.4 PROGRAMMING PARAMETERS ON THE K240

The programming of the K240 operating parameters runs through key board and display on the control electronic board.

The automation is provided with standard pre-set parameters that, in most of the cases, appear to be suitable for a proper operation. However, the control circuit board is designed to offer maximum versatility, and for that reason, there are many parameters that can be modified by the installer to satisfy various needs. To change the parameters of automation do as follows:

- press **ENTER** until you read the symbol/letter of the desired parameter [left display];
- after displaying the parameter value [center and right display] press **UP** repeatedly to increase the value, or **DOWN** to decrease it;
- wait about 10 seconds for automatic memorization or press **ENTER** to set another parameter.



PROGRAMMABLE PARAMETERS		VALUE
<b>A</b>	<b>MOTOR FORCE</b>	1-2-3
<b>b</b>	<b>OPENING ACCELERATION</b>	1-5
<b>c</b>	<b>CLOSING ACCELERATION</b>	1-5
<b>C</b>	<b>BRAKING ON OPENING</b>	1+10
<b>d</b>	<b>BRAKING ON CLOSING</b>	1+10
<b>E</b>	<b>OPENING SPEED</b>	10+55 cm/s
<b>F</b>	<b>CLOSING SPEED</b>	10+55 cm/s
<b>G</b>	<b>OPENING APPROACH SPEED</b>	1+10 cm/s
<b>h</b>	<b>CLOSING APPROACH SPEED</b>	1+10 cm/s
<b>H</b>	<b>OPENING APPROACH SPACE</b>	1+40 cm
<b>i</b>	<b>CLOSING APPROACH SPACE</b>	1+40 cm
<b>L</b>	<b>PARTIAL OPENING</b>	5+95%
<b>M</b>	<b>TOTAL AUTOMATIC RECLOSING TIME</b>	0+60 s
<b>n</b>	<b>PARTIAL AUTOMATIC RECLOSING TIME</b>	0+60 s
<b>o</b>	<b>JOG KEY AUTOMATIC RECLOSING TIME</b>	0+60 s
<b>O</b>	<b>MANUAL AUTOMATIC OPENING</b> [with value 0 = holding force on closed]	0+10 cm
<b>PF</b>	<b>PHOTOCELL INPUT LOGIC</b> [C = contacts closed]	O-C
<b>Pr</b>	<b>RADAR INPUT LOGIC</b> [O = contacts open] [C = contacts closed]	O-C
<b>PL</b>	<b>PL = LATERAL SECURITY INPUT LOGIC</b> [C = contacts closed]	O-C
<b>q</b>	<b>DOOR BLOCK LOGIC</b> [OF = Off] - [CT = close with power] - [ST = close without power]	OF-CT-ST
<b>r</b>	<b>DOOR BLOCK OPERATING MODE</b> [B0 = on with switch on closed] [B1 = on with switch on closed; entry only; exit only] [B2 = one with switch on closed; entry only; exit only; entry/exit]	B0-B1-B2
<b>S</b>	<b>BATTERY OPERATION</b> [SC = continuous service] - [AP = emergency opening] - [CH = emergency closing]	SC-AP-CH
<b>t</b>	<b>EMERGENCY OPENING MODE WITH BATTERY</b> [E0 = open with switch on or off] [E1 = no open with switch on close] [E2 = no open with switch on close; entry only; exit only]	E0-E1-E2
<b>u</b>	<b>BATTERY SUPERVISION and CHARGE TEST</b> [OF = Off] [ON = On]	OF-ON
<b>U</b>	<b>PHOTOCELL TEST</b> [OF = no active] [ON = active]	OF-ON
<b>Y</b>	<b>DYNAMIC PARTIAL OPENING</b> [0 = no active] [1+60 s = active + timer]	0+60 s

- ☒ If the battery is not installed, set parameter "u" as OFF
- ☒ If the door block is not installed, set parameter "q" as OFF
- ☒ If the photocell test is not used, set parameter "U" as OFF
- ☒ Parameters PF, Pr and PL are displayed on the left and central monitors; the monitor on the right displays the value of the parameter and it can be adjusted using the UP and DOWN keys.

**IMPORTANT:** To guarantee correct operation of the automation, parameters PF and PL must be set in [C = contact closed] mode only and cannot be modified. Parameter Pr, by default, is set on [O = contact open]; set this parameter in [C= contact closed] only if the radar functions with reverse logic.

## 5.5 LIST OF MESSAGES AND ALARMS

### STATUS MESSAGES

<b>CH</b>	CLOSE FUNCTION SELECTION
<b>SE</b>	ENTRY ONLY FUNCTION SELECTION
<b>SU</b>	EXIT ONLY FUNCTION SELECTION
<b>EU</b>	ENTRY/EXIT FUNCTION SELECTION
<b>PA</b>	PARTIAL OPENING FUNCTION SELECTION
<b>AP</b>	ALWAYS OPEN FUNCTION SELECTION
<b>SE</b>	MOTOR STOP SAFETY DEVICE
<b>SL</b>	LATERAL SECURITY
<b>FE</b>	CLOSURE/PHOTOCELL SAFETY DEVICE
<b>JO</b>	JOG KEY / EMERGENCY
<b>RE</b>	EXTERNAL RADAR IMPULSE
<b>RI</b>	INTERNAL RADAR IMPULSE
<b>Ed</b>	HOLDING FORCE ON CLOSED
<b>Eb</b>	BATTERY TEST
<b>EF</b>	PHOTOCELL TEST

### ALARM MESSAGES

<b>oA</b>	OBSTACLE DURING OPENING
<b>oC</b>	OBSTACLE DURING CLOSING
<b>nL</b>	POWER MAINS 230V INTERRUPTED / OFF
<b>EE</b>	ENCODER / MOTOR BREAKDOWN / DOOR BLOCKED
<b>Ebt</b>	BATTERY INTERRUPTED / MALFUNCTION / NOT PRESENT
<b>EFt</b>	PHOTOCELL INTERRUPTED / MALFUNCTION / NOT PRESENT
<b>Edr</b>	WRONG MOTOR DIRECTION / POLES INVERTED
<b>Pb</b>	LOCKED DOOR / ENGINE FAILURE
<b>EPH</b>	OVERLOAD DURING RESET OPERATIONS

## 5.6 PROGRAM SELECTION WITH KNOB

The program selection knob mod. MS1 serves to select different operating modes of the door using a knob. The program selected is signaled by lighting the respective LED.

The following is a description of the functions that can be programmed:



**CLOSED** - The door closes automatically from whatever position it is in, all the sensors are disabled and the door block is on.



**ENTER ONLY** - The internal exit sensor is disabled, the external entry sensor is enabled and the door block is on.



**EXIT ONLY** - The external entry sensor is disabled, the internal exit sensor is enabled and the door block is on.



**TOTAL ENTRY/EXIT** - The external/internal sensors are disabled, the door block is off and the automatic opening of the door is total.



**PARTIAL ENTRY/EXIT** - The external/internal sensors are enabled, the door block is off and the automatic opening of the door is reduced.



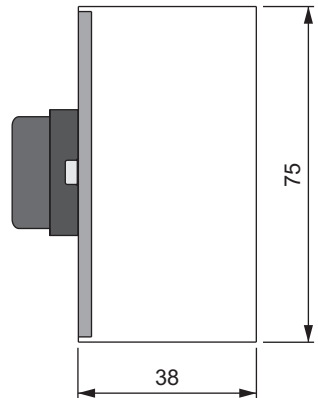
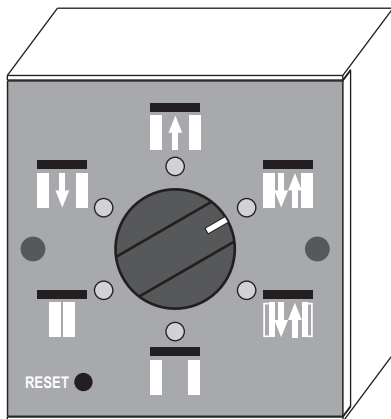
**OPEN** - The door opens automatically from whatever position it is in, and remains blocked with the door open.



**RESET** - Resets the electronic control circuit and switch.

Fig. 41

Dimensions (mm): 75 x 75 x 38



## 5.7 DIGITAL PROGRAM SWITCH

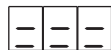
The switch with digital keys, model DS1, for surface installation, serves to select different operating modes of the door using the keys. The program function selected is signaled on the luminous display.

To set the door functions press **P2** or **P3**

To open the door in case of need press and release **P1**



To block operation of the keys hold **P1** down for about 4 seconds. When the three vertical bars appear, release the key.



To release operation of the keys hold **P1** down for about 4 seconds. When the three horizontal bars appear, release it

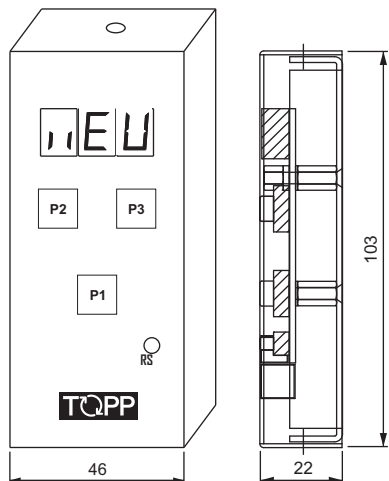


Vertical bar symbols = keys released



Horizontal bar symbols = keys blocked

Fig. 42



P1 = open – keys blocked  
 P2 = program selection down  
 P3 = program selection up

RS = reset key



**CLOSED** - The door closes automatically from whatever position it is in, all the sensors are disabled and the door block is on.



**ENTER ONLY** - The internal exit sensor is disabled, the external entry sensor is enabled and the door block is on.



**EXIT ONLY** - The external entry sensor is disabled, the internal exit sensor is enabled and the door block is on.



**TOTAL ENTRY/EXIT** - The external/internal sensors are disabled, the door block is off and the automatic opening of the door is total.



**PARTIAL ENTRY/EXIT** - The external/internal sensors are enabled, the door block is off and the automatic opening of the door is reduced.



**OPEN** - The door opens automatically from whatever position it is in, and remains blocked with the door open.

**RESET** - Resets the electronic control circuit and switch.

## 6.1 MAINTENANCE

Any repairs on the automation or its parts must be made exclusively by the manufacturer's qualified experts. TOPP is not liable for repairs made by the user or by unauthorized persons. All operations of maintenance, except functional alterations, must be made with the door open and the power off (including the emergency battery).

It is necessary to provide routine maintenance of the automation according to the following schedule:

**Every 6 months:**

- clean the glide surface of the carriages and wheels, using a cloth lightly moistened with solvent;
- clean the sensors and photocells with non-abrasive detergents;
- make sure there are no uncovered areas in the vicinity of the mobile doors that are not detected by the sensors;
- verify the correct operation of the photocells, if any, the blocking system and their fastenings;
- check the belt tension, the stability of the automation and the tension of all the screws;
- check the correct alignment of the doors and position of the door on the jamb when closed;
- check the connections and electric wiring;
- with the automation powered, check the stability of the door ensuring that the movement is regular without friction; disconnect the power supply and check that the emergency battery system opens the doors in the entirety of the passageway.

**Every 24 months:**

- if worn, replace the central gaskets and brushes on the doors.

**Every 48 months:**

- replace the emergency battery system (after disconnecting the power supply).
- ✎ The duration of the battery pack is affected by the environmental and functional conditions of the automation.

**Every 500,000 cycles:**

- replace the rubber limit stops on the carriages.

**Every 1,000,000 cycles:**

- replace the glide belt;
- replace the carriage wheels.

If, after making the checks described above, there should be any malfunctions, contact the TOPP service department

## 6.2 ACCESSORIES AND SPARE PARTS ON REQUEST

Do not use spare parts and accessories that are not original as this could affect the safety and efficiency of the automation and invalidate the warranty. Original spare parts and accessories must be requested exclusively from the authorized retailer or directly from the factory, communicating the type, model, serial number and year of construction of the automation:

- N.2 Infrared sensors (mod. IS1 and IS2);
- N.2 Microwave sensors (mod. WS1);
- N.1 Digital program selector (mod. DS1);
- N.1 Program selection knob (mod. MS1);
- N.1 Program selection knob (mod. KC1);
- N.1 Electromechanical door block;
- N.2 Miniaturized photocells (mod. F1 and mod F2);
- N.2 Ultra flat wall button;
- Antipanic door opener (simple or complete);
- System for glass door.

Should arise the need to use accessories other than those mentioned, the installer can apply directly to our technical support service.

## 6.3 DEMOLITION

Demolition of the automation must be handled in respect of the legislation in force on the subject of environmental safeguards. This means that the parts of the automation must be separated by type of material.

## 6.4 TROUBLESHOOTING

PROBLEM	REMEDY
When the display is switched on, the electronic control circuit does not switch on	Check the mains voltage 230V, the contacts on the electronic control circuit, transformer voltage, fuse.
When switched on, the display on the circuit is on but the door does not move	Check the 24V power supply of the peripherals, photocell contacts, and NO-NC logic, motor stop and closure safety devices. After changing the input logic on the safety devices perform a reset impulse
When switched on, the display on and the door moves but stops after a few centimeters	Check for possible friction in the glide, motor/thrust force to increase, encoder
After opening, the door stays in the open position	Check the photocells and their contacts, the radars and their contacts, check for possible friction in the glide, battery discharged
During closure, the door reopens by itself repeatedly	Check the position or sensitivity of the radar, alignment of the photocells, possible friction in the glide
The door bangs against the stop when opening or closing, without slowing	Check and increase the approach and/or braking distance, rememorize the movement of the door, check for motor and/or encoder breakdown
During opening or closing the door is excessively noisy	Check that there are no scraps on the glide rail, check carriage alignment, glide wheels, runners on the floor.
With functions set by the switch the door does not open	Check the radar contacts, electromechanical block, switch contacts
During closure, the door reopens by itself repeatedly	Check for possible permanent friction on the doors, malfunction of the electronic control circuit, operating parameters
The door opens slowly and closes normally	Check the lateral safety contacts and jumper J24, check for possible obstacle and/or friction in opening
The door does not function and the display of the control circuit permanently shows symbols, numbers or letters	Check the malfunction signal consulting the list of messages and alarms

TOPP S.p.A.  
via L. Galvani, 59  
36066 Sandrigo (VI)  
ITALIA



*declares that the electrical device*

*defined as: ELECTROMECHANICAL AUTOMATION FOR LINEAR SLIDING  
DOORS WITH ONE OR TWO PANELS*

*type: K240*

*Serial number and year of construction: see rating plate and CE marking  
applied to automation*

*complies with the terms of the following directives:*

*2006/95/CE*

*Low Voltage Directive: electrical material designed for use within certain voltage limits*

*2004/108/CE*

*Electromagnetic Compatibility Directive: concerning the harmonization of legislations  
among the member countries relative to electromagnetic compatibility.*

*and also declares that the following harmonized standards have been applied:*

*EN 61000-6-2*

*EN 61000-6-3*

*EN 50366*

*EN 60335-1*

*The automation for linear sliding doors mod.K240, subject of this declaration, may not be  
started up and used in the absence of the CE conformity certificate type A, that must be  
supplied by the installer.*

*Date: Sandrigo, 10/01/2008*

*Matteo Cavalcante*





TOPP SPA  
Via Galvani, 59 - 36066 Sandrigo (VI) - Italia  
Tel. +39 0444 656700 - Fax +39 0444 656701  
Info@topp.it - www.topp.it